

The logo for ETENON FITNESS features a stylized 'E' composed of three vertical bars of increasing height, with the leftmost bar being red and the other two white. To the right of this symbol, the word 'ETENON' is written in a large, bold, white, italicized sans-serif font. Below 'ETENON', the word 'FITNESS' is written in a smaller, white, italicized sans-serif font. The entire logo is set against a dark grey background with a repeating, embossed pattern of the word 'FITNESS' in a light grey color.

# ETENON FITNESS

Nº 1. EDICIÓN 1/2024

CARDIO & STRENGTH EQUIPMENT

[WWW.ETENONFITNESS.COM](http://WWW.ETENONFITNESS.COM)



RODAR GYM



NPV TRAINING



DISEÑADO POR Y PARA PROFESIONALES  
DESIGNED BY PROFESSIONALS FOR PROFESSIONALS



### Proyecto a medida

Asesoramiento en la distribución óptima de los espacios para generar comodidad y satisfacción en la experiencia de los usuarios y fomentar el crecimiento de tu negocio.

### Customized project

Advice on the optimal distribution of spaces to generate comfort and satisfaction in the user experience and promote the growth of your business.



### Servicio postventa

Ponemos a tu servicio una red de 40 técnicos cualificados distribuidos por toda la geografía española y disponibilidad de repuestos para ofrecer un servicio rápido y eficaz

### After-sales service

We put at your service a network of 40 qualified technicians distributed throughout Spain and availability of spare parts to offer a fast and efficient service.



### Agilidad y disponibilidad

Almacenes de 30.000m<sup>2</sup> para ofrecer a los clientes una amplia disponibilidad de stock y la máxima agilidad en el envío de pedidos.

### Agility and availability

Warehouses of 30,000 sqm to offer customers a wide availability of stock and maximum agility in the shipment of orders.



### Atención personalizada

Los comerciales y distribuidores de zona prestan asesoramiento a lo largo de todo el proceso, desde el estudio inicial del proyecto hasta la apertura del centro y futuras necesidades del mismo.

### Personalized attention

Sales representatives and area distributors provide advice throughout the entire process, from the initial study of the project to the opening of the centre and its future needs.



### Soporte de Marketing

Nuestra mayor satisfacción es contribuir al éxito de tu negocio. Ofrecemos herramientas y acciones para dar soporte a la captación y fidelización de tus clientes.

### Marketing support

Our greatest satisfaction is to contribute to the success of your business. We offer tools and actions to support your customer acquisition and loyalty.



### Innovación y tendencias

Siempre a la vanguardia de las nuevas tendencias de entrenamiento, a través de nuestros embajadores y atletas y de los viajes internacionales y la experiencia de nuestro equipo, para ofrecer a los clientes equipamiento innovador y con la mejor biomecánica.



### Innovation and trends

Always at the forefront of new training trends, through our ambassadors and athletes and the international travel and experience of our team, to offer customers innovative equipment with the best biomechanics.





# ÍNDICE / INDEX

6	CARDIO	<b>CARDIO</b>	
16	INDOOR CYCLING		
18	CARDIO HIIT		
20	PC20 SERIES	<b>STRENGTH</b>	
28	PC60 SERIES		
36	M5 SERIES		
42	PC50 SERIES		
46	PC70 SERIES		
50	PC10 SERIES		
52	PC40 SERIES		
53	PC30 SERIES		
54	MULTIPOWER / MULTISTATIONS		
61	SQUAT RACKS		
65	HOME		
66	PL25 SERIES		
80	PL40 SERIES		
84	PL80 SERIES		
88	PL30 SERIES		
90	PL10 SERIES		
92	PRENSAS Y JACAS		
94	LEGS PRESS AND HACK SQUATS		
	BANCOS / BENCHES		
99	PAVIMENTOS / FLOORS	<b>EQUIPMENT</b>	
105	ACCESORIOS / ACCESORIES		
114	TAQUILLAS / LOCKERS		

# SERIES V20

Esta cinta de correr de alta calidad ha sido diseñada específicamente para uso profesional, con materiales de máxima calidad que garantizan su durabilidad y resistencia en entrenamientos intensivos. Es cómoda y fácil de usar y ofrece un trabajo fluido y efectivo.

This high-quality treadmill has been designed specifically for professional use, with top quality materials that guarantee its durability and resistance in intensive training. It is comfortable and easy to use and offers smooth and effective work

CARDIO



MOTOR:  
AC 6 HP



VELOCIDAD / SPEED:  
MAX. 25 KM/H.



INCLINACIÓN / INCLINATION:  
-3 - 20 %

## V20 CINTA PROFESIONAL PROFESSIONAL TREADMILL

- Pantalla Led integrada.
- Funciones display: tiempo, velocidad, inclinación, distancia, pulso y calorías.
- 4 programas de entrenamiento. Vatios, Intervalos, Quemar Grasa, Cardio.
- Motor: AC con pico 6.0CV. Menos impacto, menos ruido, mayor vida útil y mayor par.
- Variador de sistema: Siemens
- Controles rápidos de inclinación y velocidad.
- Velocidad de 0.5 a 25 km/h.
- Inclinación de -3% a 20%.
- Control de pulso en agarre para manos e inalámbrica por bluetooth.
- Función de conexión y audio por Bluetooth. El sistema de audio que presenta la computadora es de alta fidelidad y proporciona función de carga para smartphone a través de USB (5V-2A).
- Botón de parada de emergencia.
- Soporte para tablet o smartphone.
- Apagado automático al notar la inactividad del usuario en un rango de 10 minutos.
- Banda autolubricada.
- Sistema de amortiguación y absorción de impactos smooth deck. Este sistema está

- formado por: nano capa resistente al desgaste, capa absorbente de ruido PRP, capa absorbente de cojín, capa absorbente de ruido EVA y en su base una capa inferior sólida final.
- Plataforma de rodadura doble de alta resistencia, alta densidad y resistente a la abrasión.
- Correa antiestática, resistente al desgaste y antideslizante.
- Rodillo delantero y trasero 30 x 90 mm.

- Integrated Led display.
- Display functions: time, speed, incline, distance, pulse and calories.
- 4 training programs. Watts, Intervals, Burn Fat, Cardio.
- Motor: With peak 6.0CV. Less impact, less noise, longer life and greater torque.
- System drive: Siemens
- Quick tilt and speed controls.
- Speed from 0.5 to 25 km/h.
- Incline from -3% to 20%.
- Pulse control on hand grip and wireless Bluetooth.
- Bluetooth connection and audio function. The audio system that the computer features is high fidelity and provides smartphone charging function via USB (5V-2A).
- Emergency stop button.
- Support for tablet or smartphone.
- Automatic shutdown upon noticing user inactivity within a range of 10 minutes.
- Self-lubricated belt.
- Smooth deck cushioning and shock absorption system. This system is made up of: wear-resistant nano layer, PRP noise-absorbing layer,

- cushion absorbing layer, EVA noise-absorbing layer and at its base a final solid bottom layer.
- High-strength, high-density, abrasion-resistant double tread.
- Anti-static, wear-resistant and non-slip strap.
- Front and rear roller 30 x 90 mm.

DIMENSIONES | DIMENSIONS:  
222 x 98.5 x 148.5 cm.

PESO | WEIGHT:  
205 kg.

SUPERFICIE DE CARRERA / RUNNING SURFACE:  
157 x 58 cm.

PESO MÁXIMO DE USUARIO / MAXIMUM USER WEIGHT:  
181 kg.

# SERIES V10



MOTOR:  
AC. 6 HP







VELOCIDAD / SPEED:  
MAX. 22 KM/H.



INCLINACIÓN / INCLINATION:  
-3 - 18 %

## V10 / V10T CINTA PROFESIONAL PROFESSIONAL TREADMILL

- Pantalla LED 15,6" (V10).
- Información en display: Tiempo, velocidad, distancia, calorías, pulso, RPM e inclinación.
- 4 programas de entrenamiento: Vatios, Intervalos, Quemar Grasa, Cardio.
- Motor: AC con pico 6.0 CV.
- Velocidad: 0.5 a 22 km/h.
- Banda suave y silenciosa a cualquier velocidad.
- Inclinación de -3% a 18%.
- Monitorización del ritmo cardíaco.
- Control de pulso por contacto.
- Sistema de emergencia STOP. Bloqueo rápido de emergencia, para un ejercicio más seguro.
- Conectores USB, HDMI.
- Conector USB tipo A para carga de dispositivos.
- Incluye soporte para tableta o teléfono inteligente.
- Banda inalámbrica de pulso incluida.
- Altavoces Bluetooth.
- Pasamanos resistentes al sudor, antideslizantes y de alta calidad (PU).
- 15.6" LED screen.
- Information on display: time, speed, distance, calories, pulse and RPM and inclination.
- 4 training programmes: Watts, Intervals, Burn Fat, Cardio.
- Motor: With peak 6.0CV.
- Speed: 0.5 to 22 km/h.
- Smooth and silent band at any speed.
- Inclination from -3% to 18%.
- Heart rate monitoring.
- Contact pulse control.
- STOP emergency system. Quick emergency lock, for safer exercise.
- USB, HDMI plugs.
- USB Type A connector for charging devices.
- Tablet or smart phone holder.
- Wireless pulse band included.
- Bluetooth speakers.
- Sweat-resistant, non-slip and high-quality handrails (PU).

 DIMENSIONES | DIMENSIONS: 219 x 97 x 165 cm. |  PESO | WEIGHT: 198 kg. |  SUPERFICIE DE CARRERA / RUNNING SURFACE: 157 x 58 cm. |  PESO MÁXIMO DE USUARIO / MAXIMUM USER WEIGHT: 180 kg.

# SERIES V20

CARDIO



## VE20 / VE20T ELÍPTICA ELLIPTICA

- Autogenerada. (VE20).
  - Pantalla LED 15.62". (VE20).
  - Resistencia electromagnética.
  - 40 niveles de resistencia, ajuste rápido.
  - Doble opción de agarres, fijos y móviles para un ejercicio simultáneo del tren superior e inferior.
  - Pulso por contacto y sensores telemétricos.
  - Información en display: Tiempo, velocidad, distancia, calorías, pulso y RPM.
  - Botones de ajuste de resistencia en los agarres.
  - 4 Programas de entrenamiento: Vatios, Intervalos, Quemar Grasa, Cardio. (VE20).
  - Incluye soporte para tableta o teléfono inteligente.
  - Incluye botellero.
  - Estructura en acero con recubrimiento de doble capa de pintura en polvo negra.
  - Construida en tubo de 80 x 40 x 3.0 mm.
  - Plataformas de gran tamaño para mayor confort.
  - Correa de transmisión 450 PJ 8.
  - Biela resistente y de gran tamaño.
  - Carenado protector de inyección.
  - Cargador auxiliar para batería autogenerada.
  - Ruedas para transporte.
- Autogenerated. (VE20).
  - 15.62" LED display. (VE20).
  - Electromagnetic resistance.
  - 40 resistance levels, adjusted with quick keys on fixed bar.
  - Double option of grips, fixed and mobile for simultaneous exercise of the upper and lower body.
  - Contact pulse and telemetric sensors.
  - Display function: Time, speed, distance, calories, pulse and RPM.
  - Buttons to adjust the resistance on the grips.
  - 4 training programs: Watts, Intervals, Burn Fat, Cardio. (VE20).
  - Tablet or smart phone holder.
  - Bottle rack included.
  - Steel structure with double layer black powder paint coating.
  - Built in 80 x 40 x 3.0 mm tube.
  - Large platforms for greater comfort.
  - Transmission belt 450 PJ 8.
  - Strong and big size crank.
  - Injection protection chain.
  - Auxiliary charger for self-generated battery.
  - Wheels for transport.

 **DIMENSIONES | DIMENSIONS:**  
180.2 x 87.2 x 183.5 cm.

 **PESO | WEIGHT:**  
180 kg.

 **PESO MÁXIMO DE USUARIO / MAXIMUM USER WEIGHT:**  
180 kg.





## VU20 / VU20T

### BICICLETA VERTICAL

#### UPRIGHT BIKE

- Autogenerada. (VU20)
- Pantalla: 15.6" LED. (VU20)
- Resistencia electromagnética.
- 40 niveles de resistencia, ajuste rápido.
- Pulso por contacto y sensores telemétricos.
- Información en display: Tiempo, velocidad, distancia, calorías, pulso y RPM.
- Botones de ajuste de resistencia en los agarres.
- 4 Programas de entrenamiento: Vatios, Intervalos, Quemar Grasa, Cardio. (VU20).
- Incluye soporte para tableta o teléfono inteligente.
- Incluye botellero.
- Construida en tubo de 80 x 40 x 3.0 mm.
- Correas de los pedales ajustables para cualquier tamaño de pie, hasta en 9 niveles.
- Pedales de doble plataforma con correas.
- Correa de transmisión 450 PJ 8.
- Biela resistente y de gran tamaño.
- Carenado protector de inyección.
- Cargador auxiliar para batería autogenerada.
- Asiento cómodo y de gran tamaño.
- Ajuste del asiento verticalmente.
- Autogenerada. (VU20)
- Display: 15.6" LED. (VU20)
- Electromagnetic resistance.
- 40 resistance levels, adjusted with quick keys on fixed bar.
- Contact pulse and telemetric sensors.
- Display function: Time, speed, distance, calories, pulse and RPM.
- Buttons to adjust the resistance on the grips.
- 4 training programs: Watts, Intervals, Burn Fat, Cardio. (VU20).
- Tablet or smart phone holder.
- Bottle rack included.
- Built in 80 x 40 x 3.0 mm tube.
- Adjustable pedal straps for any foot size, up to 9 levels.
- Dual platform pedals with straps.
- Transmission belt 450 PJ 8.
- Strong and big size crank.
- Protective injection fairing.
- Auxiliary charger for self-generated battery.
- Big size and comfortable seat.
- Seat adjustment vertically.

 DIMENSIONES | DIMENSIONS:  
112.3 x 67.5 x 150.6 cm.

 PESO | WEIGHT:  
75 kg.

 PESO MÁXIMO DE USUARIO / MAXIMUM USER WEIGHT:  
180 kg.

## VR20 / VR20T

### BICICLETA RECLINADA

#### RECUMBENT BIKE

- Autogenerada. (VR20)
- Pantalla: 15.6" LED. (VR20)
- Resistencia electromagnética.
- 40 niveles de resistencia, ajuste rápido.
- Pulso por contacto y sensores telemétricos.
- Información en display: Tiempo, velocidad, distancia, calorías, pulso y RPM.
- Botones de ajuste de resistencia en los agarres.
- 4 Programas de entrenamiento: Vatios, Intervalos, Quemar Grasa, Cardio. (VR20).
- Incluye soporte para tableta o teléfono inteligente.
- Incluye botellero.
- Construida en tubo de 80 x 40 x 3.0 mm.
- Pedales de doble plataforma con correas que proporcionan al usuario la opción de sujetar los pies de forma segura o de entrenar sin correas.
- Correa de transmisión 450 PJ 8.
- Biela resistente y de gran tamaño.
- Carenado protector de inyección.
- Cargador auxiliar para batería autogenerada.
- Asiento cómodo y de gran tamaño.
- Ajuste del asiento horizontalmente.
- Autogenerated. (VR20)
- Display: 15.6" LED. (VR20)
- Electromagnetic resistance.
- 40 resistance levels, adjusted with quick keys on fixed bar.
- Contact pulse and telemetric sensors.
- Display function: Time, speed, distance, calories, pulse and RPM.
- Buttons to adjust the resistance on the grips.
- 4 training programs: Watts, Intervals, Burn Fat, Cardio. (VR20).
- Tablet or smart phone holder.
- Bottle rack included.
- Built in 80 x 40 x 3.0 mm tube.
- Dual platform pedals with straps give the user the option to securely hold their feet or train without straps.
- Transmission belt 450 PJ 8.
- Strong and big size crank.
- Injection protection fairing.
- Auxiliary charger for self-generated battery.
- Big size and comfortable seat.
- Seat adjustment horizontally.



 DIMENSIONES | DIMENSIONS:  
166 x 60.7 x 140 cm.

 PESO | WEIGHT:  
115 kg.

 PESO MÁXIMO DE USUARIO / MAXIMUM USER WEIGHT:  
180 kg.

## CONSOLA /DISPLAY SERIES

# V20 / V10

Todas las maquinas que vayan equipadas con la consola táctil iran conectadas a la corriente.

Consolas disponibles en los modelos VE20, VU20, VR20 y V10.

All machines equipped with the touch screen console will be connected to the power supply.

Consoles available in models VE20, VU20, VR20 and V10.

CARDIO

- Sistema Android.
- Pantalla HD IPS táctil multilinguaje (10 idiomas).
- CPU de 6 núcleos.
- Potenciómetro integrado.
- Hasta 40 niveles de resistencia.
- 8 programas de entrenamiento: manual, fitness, clásico, amortiguación, watt, distancia, calorías, quema de grasas normal o intenso y modo rendimiento.
- Medición de información esencial: calorías, distancia, tiempo, velocidad y frecuencia cardíaca.
- Conexión Wifi y posibilidad de instalación de Apps como: Instagram, Facebook, Google Chrome, Whatsapp o YouTube (y resto apps de la tienda de Play Store).
- Conexión para dispositivos móviles screen mirror.
- Modo escenario virtual: Se ajusta la velocidad y la inclinación de forma automática de acuerdo a la visión en la pantalla. (6 escenarios).
- Dispositivo compatible con tarjetas RFID.
- Dispositivo con entrada USB 2.0 para carga de dispositivos y minijack.
- Reproducción de vídeo con diversos formatos a través de unidad flash USB (formato de vídeo: h.265, h.264, VP8, MAV, WMV, AVS, h.263, MPEG4 y otros formatos de vídeo de decodificación multivideo 1080P/2160P).
- Reproducción de audio con diversos formatos MP3 en una unidad flash USB (formatos de audio compatibles: MP3, WMA, WAV, APE, FLAC, AAC, OGG, M4A, 3GPP, etc.).
- Conexión Bluetooth para el seguimiento de datos de entrenamiento del usuario.
- Entrada de conexión HDMI externa.
- Dispositivo con soporte IEEE802.11.
- Incluye soporte para tableta o teléfono inteligente.
- Cargador para móvil 5V/1A.

DISPONIBLE EN LOS MODELOS  
AVAILABLE IN MODELS  
VE20T - VU20T - VR20T - V10T

### CONSOLA TFT 15.6" HD TÁCTIL 15.6" HD TOUCH SCREEN DISPLAY



PANTALLA  
HD IPS  
IPS HD  
FULL SCREEN



CPU  
DE 6 NÚCLEOS.  
6 CORE CPU



APP DE  
ENTRETENIMIENTO  
ENTERTAINMENT  
APP



ESCENARIO VIRTUAL  
DE CARRERA  
VIRTUAL SCENE  
RUNNING

- Android system.
- Multi-language HD IPS touch screen (10 languages).
- 6-core CPU.
- Integrated potentiometer.
- Up to 40 levels of resistance.
- 8 training programmes: manual, fitness, classic, classic, damping, watt, distance, calories, normal or intense fat burning and performance mode.
- Essential information: calories, distance, time, speed and heart rate.
- Wifi connection and possibility of installing Apps such as: Instagram, Facebook, Google Chrome, Whatsapp or YouTube (and other apps from the Play Store).
- Screen mirror connection for mobile devices.
- Virtual scenes mode: Speed and inclination are adjusted automatically according to the view on the screen. (6 scenarios).
- Device compatible with RFID cards.
- Device with USB 2.0 input for device charging and mini jack.
- Video playback with various formats via USB flash drive (video format: h.265, h.264, VP8, MAV, WMV, AVS, h.263, MPEG4 and other 1080P/2160P multi-video decoding video formats).
- Audio playback with various MP3 formats on a USB flash drive (supported audio formats: MP3, WMA, WAV, APE, FLAC, AAC, OGG, M4A, 3GPP, etc.).
- Bluetooth connection for tracking user training data.
- External HDMI connection input.
- Device with IEEE802.11 support.
- Tablet or smart phone holder.
- 5V/1A mobile charger.

### CONSOLA LED 15.6" 15.6" LED DISPLAY



- Información en display: Tiempo, velocidad, distancia, calorías, pulso y RPM.
- 4 programas de entrenamiento: Vatios, Intervalos, Quemar Grasa, Cardio.
- Conector USB tipo A para carga de dispositivos.
- Incluye soporte para tableta o teléfono inteligente.

DISPONIBLE EN LOS MODELOS  
AVAILABLE IN MODELS  
VE20 - VU20 - VR20 - V10

- Display function: time, speed, distance, calories, pulse and RPM.
- 4 training programmes: Watts, Intervals, Burn Fat, Cardio.
- USB Type A connector for charging devices.
- Tablet or smart phone holder.



PANTALLA CON  
ILUMINACIÓN EN BLANCO  
WHITE LIGHT  
DISPLAY



RESPUESTA  
INSTANTÁNEA  
INSTANT  
RESPONSE

# ¡ÚNETE A LA REVOLUCIÓN!

TE OFRECEMOS UNA COLABORACIÓN ÚNICA  
PARA IMPULSAR EL CRECIMIENTO DE TU NEGOCIO



NO SOLO OBTENDRÁS EL RESPALDO DE UNA MARCA LÍDER DEL FITNESS,  
SINO QUE DISFRUTARÁS DE BENEFICIOS EXCEPCIONALES.



ESCANEA PARA MÁS INFO

**PROMOCIÓN Y VISIBILIDAD**  
**CONTENIDO CON LOS ETENON ATHLETES**  
**VENTAJAS ECONÓMICAS**  
**CENTROS 100% ETENON FITNESS**  
**MARKETING DE ALTO IMPACTO**

SE UN ETENON OFFICIAL GYM · SE UN ETENON OFFICIAL GYM · SE UN ETENON OFFICIAL GYM · SE UN ETENON OFFICIAL GYM · SE UN ETENON OFFICIAL GYM

SE UN ETENON OFFICIAL GYM · SE UN ETENON OFFICIAL GYM · SE UN ETENON OFFICIAL GYM · SE UN ETENON OFFICIAL GYM · SE UN ETENON OFFICIAL GYM

# SERIES V9

## CONSOLA DISPLAY

- Pantalla LED-DOT Matrix zona de visualización de parámetros de entrenamiento de 12".
- Botonera táctil en la parte inferior de la pantalla.
- Información en display: tiempo, velocidad, distancia, calorías, pulso y RPM
- 12 programas de entrenamiento, programa de usuario, H.R.C., programa de vatios, recuperación y grasa corporal.
- Incluye soporte para tableta o teléfono inteligente
- LED-DOT Matrix display windows: LED screen, 12" training parameter display area.
- Keypad at the bottom of the screen.
- Display function: time, speed, distance, calories, pulse and RPM
- 12 training programs, user program, H.R.C., watt program, recovery and body fat.
- Tablet or smart phone holder.



Disponibile solo con consola LED  
Available only with LED console



## VR9 BICICLETA RECLINADA RECLINANT BIKE

- Autogenerada.
- 24 niveles de resistencia, ajuste rápido en los agarres.
- 12 programas de entrenamiento, programa de usuario, H.R.C., programa de vatios, recuperación y grasa corporal.
- Pulso por contacto y sensores telemétricos.
- Incluye botellero.
- Pedales de doble plataforma con correas que proporcionan al usuario la opción de sujetar los pies de forma segura o de entrenar sin correas.
- Correa de transmisión 450 PJ 8.
- Biela resistente y de gran tamaño.
- Carenado protector de inyección.
- Cargador auxiliar para batería autogenerada.
- Asiento y respaldo cómodos y de gran tamaño.
- Ajuste del asiento horizontalmente.
- Self generator system.
- 24 resistance levels, adjusted with quick keys on the grips.
- 12 training programs, user program, H.R.C., watt program, recovery and body fat.
- Contact pulse and telemetric sensors.
- Bottle rack included.
- Dual platform pedals with straps give the user the option to securely strap their feet in or train without straps.
- Transmission belt 450 PJ 8.
- With strong and big size crank.
- Injection protection chain.
- Auxiliary charger for self-generated battery.
- With big size and comfortable seat and back rest.
- Seat adjustment horizontally.

DIMENSIONES | DIMENSIONS: 176 x 59.3 x 125.5 cm. PESO MÁXIMO DE USUARIO / MAXIMUM USER WEIGHT: 160 kg.

PESO | WEIGHT: 78.5 kg.

## VU9 BICICLETA VERTICAL UPRIGHT BIKE

- Autogenerada.
- 24 niveles de resistencia, ajuste rápido en los agarres.
- 12 programas de entrenamiento, programa de usuario, H.R.C., programa de vatios, recuperación y grasa corporal.
- Pulso por contacto y sensores telemétricos.
- Incluye botellero.
- Pedales de doble plataforma con correas que proporcionan al usuario la opción de sujetar los pies de forma segura o de entrenar sin correas.
- Correas de los pedales ajustables para cualquier tamaño de pie, hasta en 9 niveles.
- Correa de transmisión 450 PJ 8.
- Biela resistente y de gran tamaño.
- Carenado protector de inyección.
- Cargador auxiliar para batería autogenerada.
- Asiento cómodo y de gran tamaño.
- Ajuste del asiento verticalmente.
- Self generator system.
- 24 resistance levels, adjusted with quick keys on the grips.
- 12 training programs, user program, H.R.C., watt program, recovery and body fat.
- Contact pulse and telemetric sensors.
- Bottle rack included.
- Dual platform pedals with straps give the user the option to securely strap their feet in or train without straps.
- Adjustable pedal straps for any foot size, up to 9 levels.
- Transmission belt 450 PJ 8.
- With strong and big size crank.
- Injection protection chain.
- Auxiliary charger for self-generated battery.
- Big size and comfortable seat.
- Seat adjustment vertically.

DIMENSIONES | DIMENSIONS: 128.8 x 56 x 156 cm. PESO | WEIGHT: 54 kg.



PESO MÁXIMO DE USUARIO / MAXIMUM USER WEIGHT: 160 kg.



## VC9

### ESCALERA STAIRCLIMBER

- Alimentación a la red eléctrica.
- Información en display: Tiempo, distancia, programas, frecuencia cardiaca, calorías, resistencia, RPM y velocidad.
- Velocidad de carrera: 0.5 - 3.2 km/h.
- Consola LED con 8 programas de entrenamiento.
- 15 niveles de resistencia, ajuste rápido.
- Pulso por contacto y sensores telemétricos.
- Sensor de emergencia: cuando el usuario pone el pie por debajo del sensor, la máquina se para de manera automática.
- Incluye botellero.
- Estructura en acero Q235.
- Escalones en acero Q235 con superficie de caucho.
- Carenado en plástico de inyección de alta calidad.
- Mains power supply.
- Information on display: Time, distance, programmes, heart rate, calories, endurance, RPM and speed.
- Running speed: 0.3 - 2 km/h.
- LED console with 8 training programmes.
- 15 resistance levels, quick adjustment.
- Contact pulse and telemetric sensors.
- Emergency sensor: when the user puts his foot under the sensor, the machine stops automatically.
- Bottle rack included.
- Structure in Q235 steel.
- Steps in Q235 steel with rubber surface.
- High-quality injection moulded plastic fairing.

 **DIMENSIONES | DIMENSIONS:** 158 x 84.5 x 211.5 cm. |  **PESO MÁXIMO DE USUARIO / MAXIMUM USER WEIGHT:** 160 kg.



 **PESO | WEIGHT:** 203 kg. | **LARGO Y ANCHO PELDAÑO | LONG AND WIDE STEP:** 55.5 x 25.5 cm.



## VE9

### ELÍPTICA ELLIPTICAL

- Autogenerada.
- 24 niveles de resistencia, ajuste rápido en los agarres.
- 12 programas de entrenamiento, programa de usuario, H.R.C., programa de vatios, recuperación y grasa corporal.
- Pulso por contacto y sensores telemétricos.
- Incluye botellero.
- Doble opción de agarres, fijos y móviles para un ejercicio simultáneo del tren superior e inferior.
- Correa de transmisión 450 PJ 8.
- Biela resistente y de gran tamaño.
- Plataformas de gran tamaño para mayor confort.
- Carenado protector de inyección.
- Cargador auxiliar para batería autogenerada.
- Estructura en acero con recubrimiento de doble capa de pintura en polvo negra.
- Distancia entre pedales: 20 cm.
- Longitud de zancada: 52 cm.
- Ruedas para transporte.
- Self generator system.
- 24 resistance levels, adjusted with quick keys on the grips.
- 12 training programs, user program, H.R.C., watt program, recovery and body fat.
- Contact pulse and telemetric sensors.
- Bottle rack included.
- Double option of grips, fixed and mobile for a simultaneous exercise of the upper and lower body.
- Transmission belt 450 PJ 8.
- With strong and big size crank.
- Big size and comfortable platforms.
- Injection protection chain.
- Auxiliary charger for self-generated battery.
- Steel structure with coating of double layer of black powder paint.
- Distance between pedals: 20 cm.
- Stride length: 52 cm.
- Wheels for transport.

 **DIMENSIONES | DIMENSIONS:** 220 x 62.2 x 167.7 cm. |  **PESO | WEIGHT:** 85.6 kg.

 **PESO MÁXIMO DE USUARIO / MAXIMUM USER WEIGHT:** 160 kg.



# SERIES V8

Tus clientes disfrutarán de los beneficios del running con la máxima estabilidad, una sensación muy natural de la zancada y una gran absorción del impacto.

La cinta V8 se adapta a la intensidad de cada entrenamiento llegando a los 22 Km por hora y 18 niveles de inclinación, para los runners más exigentes.

Your clients will enjoy the benefits of running with maximum stability, a very natural stride sensation and great shock absorption.

The V8 treadmill adapts to the intensity of each workout, reaching up to 22 km per hour and 18 levels of incline, for the most demanding runners.



MOTOR:  
AC. 6 CV.



VELOCIDAD / SPEED:  
MAX. 22 KM/H.



INCLINACIÓN / INCLINATION:  
0-18 NIVELES / LEVELS



PROGRAMAS / PROGRAMS:  
24



V8

- Pantalla: 18,5" panorámica Led Matrix.
- Compatible con Kinomap y Zwift
- Display: 18.5 "panoramic Led Matrix.
- Compatible with Kinomap and Zwift



V8T

- Pantalla: 18.5". Táctil, interactiva y panorámica
- Programas: calorías, paisaje, distancia, tiempo, pulsómetro, inicio rápido. Bluetooth. Wifi.
- Display: 18.5". Touch, interactive and panoramic.
- Programs: calories, landscape, distance, time, heart rate monitor mode, quick start. Bluetooth. Wifi.

## V8 / V8T

### CINTA PROFESIONAL PROFESSIONAL TREADMILL

- Funciones display: tiempo, velocidad, inclinación, distancia, pulso y calorías.
- 24 programas de entrenamiento.
- Control de la inclinación y la velocidad en pasamanos frontal.
- Control de pulso por contacto e inalámbrico por bluetooth.
- Sistema de emergencia STOP.
- Velocidad de 1.0 a 22 km/h.
- Entrada para mini jack.
- Conexión USB, MP3 y SD.
- Función podómetro.
- Reserva de energía modo ahorro.
- Ruedas para transporte.
- Incluye botellero.
- Banda autolubrificada con sistema de amortiguación smooth deck para minimizar el impacto durante la carrera.
- Display functions: time, speed, inclination, distance, pulse and calories.
- 24 training programs.
- Inclination and speed control in front handlebar.
- Pulse control in handgrip and wireless by bluetooth.
- STOP emergency system.
- Speed from 1.0 to 22 km/h.
- Mini jack connector.
- USB, MP3 and SD connection.
- Pedometer function.
- Power reserve saving mode.
- Wheels for transport.
- Bottle rack included.
- Self-lubricated band with smooth deck damping system to minimize impact during the race.

DIMENSIONES | DIMENSIONS:  
216 x 89 x 148 cm.

PESO | WEIGHT:  
166 kg.

SUPERFICIE DE CARRERA / RUNNING SURFACE:  
150 x 55 cm.

PESO MÁXIMO DE USUARIO / MAXIMUM USER WEIGHT:  
180 kg.

# SERIES V7



MOTOR:  
AC. 5 HP



VELOCIDAD / SPEED:  
MAX. 20 KM/H.



INCLINACIÓN / INCLINATION:  
0 - 15 %

## V7 CINTA TREADMILL

- Panel táctil con pantalla LED de altas prestaciones.
- Información en display: Tiempo, velocidad, distancia, pulso, calorías e inclinación.
- 4 programas de entrenamiento. Varios, Intervalos, Quemar Grasa, Cardio.
- Control de pulso por contacto.
- Pasamanos resistentes al sudor, fabricados en PU.
- Sistema de emergencia STOP.
- Banda ergonómica de alta intensidad, diseñada para ofrecer una mayor seguridad.
- Tecnología de absorción de plataforma completa.
- Motor: AC con pico 5.0 CV.
- Velocidad máxima 1.0 km/h a 20 km/h.
- Inclinación de hasta 15 niveles.
- Estructura construida con columnas gruesas de acero inoxidable de una sola pieza en forma de U.
- Pintura electrostática de alta precisión Nordson y acabado con textura de alta calidad.
- Soporte para apoyar teléfono o tablet.
- Incluye botellero.
- Banda inalámbrica de pulso incluida.
- Altavoces Bluetooth.
- Touch panel with high-performance LED screen.
- Display function: Time, speed, distance, heart pulse, calories and inclination.
- 4 training programs. Watts, Intervals, Burn Fat, Cardio.
- Contact pulse control.
- Sweat-resistant handrails, made of PU.
- STOP emergency system.
- High intensity ergonomic band, designed to offer greater safety.
- Full platform absorption technology.
- Motor: AC with peak 5.0 CV.
- Maximum speed 1.0 km/h to 20 km/h.
- Tilt up to 15 levels.
- Structure constructed of thick one-piece U-shaped stainless steel columns.
- Nordson high-precision electrostatic paint and high quality textured finish.
- Support for phone or tablet.
- Bottle rack included.
- Wireless pulse band included.
- Bluetooth Speakers



DIMENSIONES | DIMENSIONS:  
230 x 91 x 153 cm.



PESO | WEIGHT:  
136.5 kg.



SUPERFICIE DE CARRERA / RUNNING SURFACE:  
145 x 52 cm.



PESO MÁXIMO DE USUARIO / MAXIMUM USER WEIGHT:  
130 kg.



## PR070

### ION.7

- Chasis de acero con recubrimiento de doble capa de pintura en polvo anticorrosión.
- Sistema de freno con regulación de la intensidad por fricción mediante zapata de cuero.
- Disco de inercia de 24 kg.
- Pedalier extra-resistente sellado en acero con 3 rodamientos.
- Sistema resistente de transmisión mediante correa Poly-V Plus, potente y muy silenciosa. No necesita mantenimiento.
- Tija y potencia de acero inoxidable.
- Manillar de carretera multiposición. Ø 37 mm.
- Sillín de vinilo PVC.
- Asiento y manillar regulables vertical y horizontalmente.
- Pedales mixtos. SPD-trekking.
- Bloqueo rápido de emergencia, para un ejercicio más seguro.
- Porta-botellín lateral siempre a mano, para una hidratación constante durante el ejercicio.
- Ruedas en la parte delantera para un fácil transporte.
- 4 Patas ajustables en los caballetes frontal y trasero, para garantizar la máxima estabilidad. Tacos de goma para evitar roces con el suelo.
- Protección en chasis y patas para proteger la pintura durante los ejercicios de estiramiento.
- Diseñada con estudio biomecánico garantiza movimientos suaves, naturales, y con gran concentración muscular.
- Steel chassis with double-layer anti-corrosion powder coating.
- Brake system with friction intensity regulation using leather shoe.
- 24 kg flywheel.
- Extra-strong sealed steel bottom bracket with 3 bearings.
- Resistant Poly-V Plus belt transmission system, powerful and very quiet. No maintenance required.
- Stainless steel stem and seatpost.
- Multi-position road handlebar. Ø 37 mm.
- PVC vinyl saddle.
- Seat and handlebars adjustable vertically and horizontally.
- Mixed pedals. SPD-trekking.
- Quick emergency lock, for safer exercise.
- Side bottle holder always at hand, for constant hydration during exercise.
- Wheels on the front for easy transportation.
- 4 adjustable legs on the front and rear stands, to ensure maximum stability. Rubber pads to avoid rubbing with the ground.
- Protection on chassis and legs to protect the paint during stretching exercises.
- Designed with a biomechanical study, it guarantees smooth, natural movements, and with great muscle concentration.

**DIMENSIONES | DIMENSIONS:**  
108 (min.)/130 (max.) x 64 x 108 (min.)/127 (max.) cm.

**PESO MÁXIMO DE USUARIO / MAXIMUM USER WEIGHT:**  
160 kg.

**PESO | WEIGHT:**  
70 kg.





## PR060 ION.6

- Chasis de acero con recubrimiento de doble capa de pintura en polvo anticorrosión.
- Sistema de resistencia magnético.
- Disco de inercia de 15 kg.
- Pedalier extra-resistente, sellado en acero con 3 rodamientos.
- Sistema resistente de transmisión mediante correa Poly-V, potente y muy silenciosa. No necesita mantenimiento.
- Tija y potencia de acero inoxidable.
- Manillar tipo carrera multiposición. Ø 34.5 mm.
- Sillín de vinilo PVC.
- Asiento y manillar regulables vertical y horizontalmente.
- Pedales mixtos. SPD-trekking.
- Bloqueo rápido de emergencia, para un ejercicio más seguro.
- Porta-botellín siempre a mano, para una hidratación constante durante el ejercicio.
- Ruedas en la parte delantera para un fácil transporte.
- 4 Patas ajustables en los caballetes frontal y trasero, para garantizar la máxima estabilidad. Tacos de goma para evitar roces con el suelo.
- Protector disco de inercia contra el sudor y los accidentes.
- Protección en chasis y patas para proteger la pintura durante los ejercicios de estiramiento.
- Diseñada con estudio biomecánico garantiza movimientos suaves, naturales, y con gran concentración muscular.
- Steel chassis with double-layer anti-corrosion powder coating.
- Magnetic resistance system.
- 15 kg flywheel.
- Extra-strong sealed steel bottom bracket with 3 bearings.
- Resistant Poly-V belt transmission system, powerful and very quiet. No maintenance required.
- Stainless steel stem and seatpost.
- Multi-position road handlebar. Ø 34.5 mm.
- PVC vinyl saddle.
- Seat and handlebars adjustable vertically and horizontally.
- Mixed pedals. SPD-trekking.
- Quick emergency lock, for safer exercise.
- Bottle holder always at hand, for constant hydration during exercise.
- Wheels on the front for easy transportation.
- 4 adjustable legs on the front and rear stands, to ensure maximum stability. Rubber pads to avoid rubbing with the ground.
- Flywheel protector against sweat and accidents.
- Protection on chassis and legs to protect the paint during stretching exercises.
- Designed with a biomechanical study, it guarantees smooth, natural movements, and with great muscle concentration.

 DIMENSIONES | DIMENSIONS:  
120 x 65 x 121 cm.

 PESO MÁXIMO DE USUARIO / MAXIMUM USER WEIGHT:  
120 kg.

 PESO | WEIGHT:  
47.4 kg.

# H501

## AIR ROWER

- Sistema de resistencia por aire y magnético.
  - 9 Niveles de resistencia.
  - Mango diseñado ergonómicamente.
  - Receptor de frecuencia cardíaca incorporado (transmisor de frecuencia cardíaca no incluido).
  - Ruedas frontales.
  - 8 Programas preestablecidos.
  - Con pantalla LCD matrix de 5.25 "x 3" con soporte para teléfono.
  - Funciones display: tiempo, distancia, remadas por minuto, metros recorridos, calorías, vatios y frecuencia cardíaca.
  - Conectividad a Kinomap y D-fit.
- Resistance system: air & magnetic.
  - 9 resistance levels.
  - Ergonomically designed handle.
  - Built-in heart rate receiver (heart rate transmitter sold separately).
  - Front wheels.
  - 8 Preset programs.
  - 5.25" x 3" Matrix LCD Display with cell phone holder.
  - Display functions: time, distance, padding per min, meters travelled, calories, watts, heart rate.
  - Connectivity to Kinomap and D-fit connectivity



**DIMENSIONES | DIMENSIONS:**  
241 x 64 x 109 cm.

**PESO | WEIGHT:**  
38 kg.

**PESO MÁXIMO DE USUARIO / MAXIMUM USER WEIGHT:**  
135 kg.

# UNLIMITED H5

# H507

## AIR RUNNER

- Autogenerado.
  - Estructura metálica con terminación con pintura electroestática.
  - Sistema individual de listones que se mueven a través de los rodillos.
  - Rueda de transmisión de aluminio.
  - Freno manual, resistencia de 0 a 4 niveles con palanca selectiva en el manillar.
  - Superficie de carrera 48 x 160 cm: está diseñada para absorber el impacto.
  - Pantalla LCD. Indicador de Tiempo, Velocidad, Distancia, Calorías, Vatios, Frecuencia cardíaca y contador de pasos.
  - 7 programas de entrenamiento.
- Self-generating.
  - Durable metal structure with electrostatic paint finish
  - Individual slat system: moving through the rollers.
  - Aluminium drive wheel.
  - Manual brake, resistance from 0 to 4 levels with selective lever on the handlebar.
  - Running surface 44 x 160 cm: designed to absorb high impacts.
  - LCD screen. Console shows: Time, speed, distance, calories, watts, heart rate and step count.
  - 7 training programs.



**DIMENSIONES | DIMENSIONS:**  
172 x 81 x 170 cm.

**PESO | WEIGHT:**  
135 kg.

**PESO MÁXIMO DE USUARIO / MAXIMUM USER WEIGHT:**  
180 kg.

**SUPERFICIE DE CARRERA / RUNNING SURFACE:**  
48 x 160 cm.



## H552

### AIR BIKE

- Sistema de resistencia ilimitada por aire, generando corrientes de aire frío mientras se pedalea.
- Funciones display: velocidad, calorías, distancia, RPM, vatios y tiempo.
- Consola digital con intervalos programables.
- Transmisión por correa y por cadena (usa ambas).
- Pedales de aluminio antideslizantes.
- Asiento cómodo y ajustable vertical y horizontalmente.
- Estructura del asiento y de los rieles de aluminio de alta calidad.
- Acabado en pintura en polvo.
- Ruedas para facilitar el transporte.
- Botellero.
- Unlimited air resistance system, generating cold air currents while pedaling.
- Display functions: speed, calories, distance, RPM, watts and time.
- Digital console with programmable intervals.
- Belt and chain drive (use both).
- Non-slip aluminum pedals.
- Comfortable and vertically and horizontally adjustable seat.
- High-quality aluminum seat and rail frames.
- Powder paint finish.
- Wheels for easy transport.
- Bottle rack.

 **DIMENSIONES | DIMENSIONS:**  
140 x 61 x 126 cm.

 **PESO | WEIGHT:**  
53.5 kg.

 **PESO MÁXIMO DE USUARIO / MAXIMUM USER WEIGHT:**  
150 kg.



## H504

### AIR SKY

- Sistema de resistencia por aire.
- 10 niveles de resistencia.
- Mangos ergonómicos que proporcionan un agarre cómodo y seguro y no absorben el sudor.
- Resistente y de fácil mantenimiento.
- Estructura de acero con terminación de pintura en polvo.
- Pantalla LCD matrix de 5.25" x 3". Funciones display: Tiempo, Distancia, Pulso, Recorrido por remada, Calorías y Vatios.
- Conectividad a Kinomap y D-fit.
- 8 programas de entrenamiento.
- Air resistance system.
- 10 resistance levels.
- Ergonomic handles that provide a comfortable and secure grip and do not absorb sweat.
- Resistant and easy to maintain.
- Steel structure with powder paint finish.
- 5.25" x 3" matrix LCD display. Display functions: Time, Distance, Pulse, Rowing, Calories and Watts.
- Kinomap and D-fit connectivity.
- 8 training programmes.

 **DIMENSIONES | DIMENSIONS:**  
126 x 59 x 219 cm.

 **PESO | WEIGHT:**  
44 kg.



## H505

### POWER BIKE

- Resistencia: Aire + Magnético.
- 32 Niveles de resistencia en total. Del 1 al 8 con resistencia por aire; del 9 al 32 con resistencia magnética.
- Asiento y manillar en aluminio con 17 posiciones regulables.
- Información consola: Tiempo, Revoluciones por minuto (RPM), tiempo/km, vatios, vatios AVG, ratio pulsaciones, distancia total, calorías, calorías/pulso cardíaco, resistencia, memoria, programas.
- El embrague permite pedalear en punto muerto como en una bicicleta normal.
- Ruedas para un fácil transporte.
- Patas ajustables para garantizar la máxima estabilidad.
- Resistance: Air + Magnetic.
- 32 resistance levels in total. 1 to 8 with air resistance; 9 to 32 with magnetic resistance.
- Aluminium seat and handlebars with 17 adjustable positions.
- Information console: Time, Revolutions per minute (RPM), time/km, watts, AVG watts, heart rate, total distance, calories, calories/heart rate, resistance, memory, programmes.
- The clutch allows you to pedal in neutral like a normal bike.
- Wheels for easy transport.
- Adjustable legs for maximum stability.

 **DIMENSIONES | DIMENSIONS:**  
122 x 47 x 127 cm.

 **PESO | WEIGHT:**  
42.4 kg.

 **PESO MÁXIMO DE USUARIO / MAXIMUM USER WEIGHT:**  
135 kg.

# SERIES PC20

La serie PC20 está formada por máquinas selectorizadas unilaterales, convergentes y duales. Tiene un diseño elegante y estético y una calidad para uso profesional. Todas las máquinas están ergonómicamente diseñadas para proporcionar un movimiento natural, maximizar la efectividad de los ejercicios y cumplen con la norma EN-957 Clase S.

## CARACTERÍSTICAS TÉCNICAS

- Estructura construida en tubo oval de acero de alta calidad de 3 mm. de espesor.
- Partes móviles montadas con pletina de 0.5 cm. de espesor.
- Partes desmontables de acero macizo con el que se evitan problemas de desgaste.
- Las máquinas están montadas sobre rodamientos (circulares o lineales) o ruedas de bronce y rodamientos.
- Brazos contrabalanceados. Anulan el peso de la parte de la estructura que hay que mover, para levantar sólo el peso seleccionado con las placas.
- Uso de sistema de levas para desarrollar un peso uniforme. Mantiene el brazo de fuerza con una resistencia constante durante todo el recorrido.
- El proceso de pintado de las máquinas se realiza en túnel de tratamiento de cuatro capas, que ofrece una absoluta garantía contra la corrosión. En la primera capa se procede al desengrasado y fosfatado en caliente. La segunda se trata de un pre fosfatado a temperatura ambiente. En la tercera se procede a fosfatar en caliente. Y por último, se cubre la estructura con pintura epoxi en polvo.
- Las placas son de acero calibrado, pintadas en negro, estas tienen anillos de teflón de una calidad superior, lo cual produce un deslizamiento correcto y evita ruidos por fricción.
- Selectores de placas magnetizados. Los imanes evitan que el selector se salga durante el ejercicio.
- Torre de placas con indicadores de peso en kg. y en lbs.
- Las barras guías son de acero inoxidable.
- Transmisión por cable reforzado de 3 mm con funda protectora de 2 mm de espesor.
- Carenados delantero y trasero en policarbonato para evitar accidentes mientras las placas están en movimiento.
- Ajustes del asiento, del respaldo y de los rodillos acolchados. Permite la adaptación de las máquinas a cualquier usuario y ayuda a realizar los ejercicios con la postura correcta.
- Selectores de ajuste de color rojo para localizarlos fácilmente.
- Agarres de goma no absorbente y antideslizante. Son altamente resistentes.
- Incluye dos bandejas de gran dimensión como soporte botellero y portaobjetos.
- Tapizado con relleno viscoelástico y polipiel antibacteriana e ignífuga.
- Pictograma explicativo sobre la postura correcta para la realización del ejercicio y los músculos implicados en el mismo.
- Peso máximo usuario: 180 kg.
- Garantía estructura: 7 años.

The PC20 series line consists of unilateral, convergent and dual selectorized machines. It has an elegant and aesthetic design and its quality is suitable for professional use. All machines are ergonomically designed to provide natural movement, maximize the effectiveness of exercises and comply with EN-957 Class S.

## TECHNICAL CHARACTERISTICS

- Built in high quality 3 mm-thick oval steel tubing.
- Movable parts mounted with a 0.5 cm. thick plate.
- Solid steel removable parts avoiding wear problems.
- The machines are mounted on bearings (circular or linear) or bronze wheels and bearings.
- Counterbalanced arms which offset the weight of the part of the structure to be moved, so the user only lifts the weight selected with the plates.
- Use of cam system to develop uniform weight. Maintains constant resistance for the power arm throughout the exercise.
- The painting process of the machines is carried out in a four-layer tunnel treatment, which offers an absolute guarantee against corrosion. The first layer is where the structure is degreased and phosphated at temperature. The second is a pre-phosphate application at room temperature. In the third, hot phosphating is carried out. And finally, the structure is covered with epoxy power coated finish.
- The plates are made of calibrated steel, painted black, they have superior quality Teflon rings, which produces a correct sliding and prevents friction noises.
- Magnetized plate selectors. The magnets prevent the selector from coming off during exercise.
- Plate tower with weight indicators in kg. and lbs.
- The guide bars are made of stainless steel.
- Transmission by 3 mm reinforced cable with a 2 mm thick protective sheath.
- Polycarbonate front and rear fairings to prevent accidents while the plates are in motion.
- Padded seat back and roller adjustments. The machines can be adapted to any user, helping them to perform the exercises from the correct posture.
- Red adjustment knobs for easy location.
- Non-absorbent and non-slip rubber grips. They are highly resistant.
- It includes two large-sized trays serving as a bottle rack and object holder.
- Upholstered with memory foam padding and antibacterial and fire retardant leatherette.
- Explanatory pictogram explaining the correct posture for the exercise and which muscles are involved.
- Maximum user weight: 180 kg.
- Structure guarantee: 7 years.

**1** Contrapeso.  
Counterbalance.

**2** Botellero y portaobjetos en la parte superior.  
Bottle and personal items holder.

**3** Torre de placas con indicadores de peso en kg. y en lbs.  
Plate tower with weight indicators in kg. and lbs.

**4** Barra guía de acero inoxidable.  
Stainless steel guide bar.

**5** Pictograma con la postura correcta para la realización del ejercicio y los músculos implicados.  
Pictogram with the correct posture for the exercises, and which muscles are involved.

**6** Selectores de ajuste de color rojo para localizarlos fácilmente.  
Red adjustment knobs for easy location.

**7** Selector de placas magnético.  
Magnetic weight selector.

**8** Tapizado con relleno viscoelástico y polipiel antibacteriana e ignífuga.  
Upholstery with viscoelastic padding fireproof and antibacterial leatherette.

**9** Carenado protector para evitar accidentes mientras las placas están en movimiento.  
Protective fairing to avoid accidents while the plates are in movement.

**10** Terminaciones cromadas.  
Chrome-plated grip ends.

**11** Agarres de goma no absorbentes y antideslizantes.  
Non-slip and non-absorbent rubber grips.





**PC2005**  
EXTENSIÓN DE CUÁDRICEPS  
LEG EXTENSION

**DIMENSIONES | DIMENSIONS:** 147.5 x 126 x 150 cm. | **PESO | WEIGHT:** 228 kg. | **CARGA DE PLACAS / PLATE LOADING:** 115.17 + 2.27 (PC20-OPT) / 117.44 kg.



**PC2018**  
FEMORAL TUMBADO  
LYING LEG CURL

**DIMENSIONES | DIMENSIONS:** 172.5 x 127.8 x 150 cm. | **PESO | WEIGHT:** 212 kg. | **CARGA DE PLACAS / PLATE LOADING:** 104.42 + 2.27 (PC20-OPT) / 106.69 kg.



**PC2006**  
FEMORAL SENTADO  
SEATED LEG CURL

**DIMENSIONES | DIMENSIONS:** 145.5 x 126.5 x 150 cm. | **PESO | WEIGHT:** 238 kg. | **CARGA DE PLACAS / PLATE LOADING:** 104.42 + 2.27 (PC20-OPT) / 106.69 kg.



**PC2024**  
MULTICADERA  
MULTHIP

**DIMENSIONES | DIMENSIONS:** 160.6 x 140.3 x 99 cm. | **PESO | WEIGHT:** 244 kg. | **CARGA DE PLACAS / PLATE LOADING:** 86.26 kg.



**PC2011**  
PRENSA SENTADO  
SEATED LEG PRESS

**DIMENSIONES | DIMENSIONS:** 186.4 x 118.4 x 150 cm. | **PESO | WEIGHT:** 346 kg. | **CARGA DE PLACAS / PLATE LOADING:** 149.82 kg.



**PC2034**  
JALÓN DORSAL  
LAT PULLDOWN

**DIMENSIONES | DIMENSIONS:** 161.4 x 134.5 x 191.7 cm. | **PESO | WEIGHT:** 306 kg. | **CARGA DE PLACAS / PLATE LOADING:** 129.27 + 2.27 (PC20-OPT) / 131.54 kg.



## PC2001

### PRESS VERTICAL CONVERGENTE

CONVERGING CHEST PRESS

DIMENSIONES | DIMENSIONS: 155.5 x 98.5 x 181.5 cm. |
 PESO | WEIGHT: 182 kg. |
 CARGA DE PLACAS / PLATE LOADING: 86.26 + 2.27 (PC20-OPT) / 88.47 kg.



## PC2002

### REMO SENTADO CONVERGENTE

CONVERGING SEATED ROW

DIMENSIONES | DIMENSIONS: 159 x 111.5 x 150 cm. |
 PESO | WEIGHT: 196 kg. |
 CARGA DE PLACAS / PLATE LOADING: 104.42 kg.



## PC2003

### PRESS DE HOMBROS CONVERGENTE

CONVERGING SHOULDER PRESS

DIMENSIONES | DIMENSIONS: 170.7 x 149.9 x 150 cm. |
 PESO | WEIGHT: 203 kg. |
 CARGA DE PLACAS / PLATE LOADING: 86.2 + 2.27 (PC20-OPT) / 88.47 kg.



## PC2022

### ELEVACIONES LATERALES

LATERAL RAISE

DIMENSIONES | DIMENSIONS: 150.6 x 98.4 x 150 cm. |
 PESO | WEIGHT: 188 kg. |
 CARGA DE PLACAS / PLATE LOADING: 113.50 + 2.27 (PC20-OPT) / 115.77 kg.



## PC2007

### CURL DE BÍCEPS

BICEPS CURL

DIMENSIONES | DIMENSIONS: 125.5 x 108.5 x 150 cm. |
 PESO | WEIGHT: 168 kg. |
 CARGA DE PLACAS / PLATE LOADING: 56 + 2.27 (PC20-OPT) / 58.27 kg.



## PC2008

### EXTENSIÓN DE TRÍCEPS

TRICEPS EXTENSION

DIMENSIONES | DIMENSIONS: 124.5 x 102 x 150 cm. |
 PESO | WEIGHT: 178 kg. |
 CARGA DE PLACAS / PLATE LOADING: 86.2 kg.



**PC2025**  
**DUAL CUÁDRICEPS/FEMORAL SENTADO**  
 DUAL QUADRICEPS/SEATED LEG CURL

**DIMENSIONES | DIMENSIONS:** 140.7 x 125 x 150 cm. | **PESO | WEIGHT:** 258 kg. | **CARGA DE PLACAS / PLATE LOADING:** 131.60 kg.



**PC2030**  
**DUAL GEMELO/SENTADILLA**  
 DUAL SQUAT/STANDING CALF

**DIMENSIONES | DIMENSIONS:** 133.2 x 117 x 151.3 cm. | **PESO | WEIGHT:** 166 kg. | **CARGA DE PLACAS / PLATE LOADING:** 122.58 + 2.27 (PC20-OPT) / 124.85 kg.



**PC2016**  
**DUAL ABDUCTOR/ADDUCTOR**  
 DUAL ABDUCTOR/ADDUCTOR

**DIMENSIONES | DIMENSIONS:** 161.7 x 67.7 x 150 cm. | **PESO | WEIGHT:** 208 kg. | **CARGA DE PLACAS / PLATE LOADING:** 104.42 + 2.27 (PC20-OPT) / 106.69 kg.



**PC2032**  
**DUAL POLEA ALTA/BAJA**  
 DUAL HIGH/LOW PULLEY

**DIMENSIONES | DIMENSIONS:** 180.8 x 121.3 x 228 cm. | **PESO | WEIGHT:** 261 kg. | **CARGA DE PLACAS / PLATE LOADING:** 104.42 + 2.27 (PC20-OPT) / 106.69 kg.



**PC2029**  
**DUAL ABDOMINAL - LUMBAR**  
 DUAL ABDOMINAL CURL - BACK EXTENSION

**DIMENSIONES | DIMENSIONS:** 131.4 x 112 x 150 cm. | **PESO | WEIGHT:** 227 kg. | **CARGA DE PLACAS / PLATE LOADING:** 108.86 kg.





**PC2014**  
**DUAL DOMINADAS/FONDOS ASISTIDOS**  
 DUAL ASSISTED CHIN-UP/DIP

**DIMENSIONES | DIMENSIONS:** 123.8 x 118.7 x 223.6 cm. | **PESO | WEIGHT:** 227 kg. | **CARGA DE PLACAS / PLATE LOADING:** 77.18 + 2.27 (PC20-OPT) / 79.45 kg.







**PC2031**  
DUAL APERTURAS/DELTOIDES  
DUAL PECTORAL FLY/REAR DELTOID

 DIMENSIONES | DIMENSIONS: 145.1 x 146.3 x 198.5 cm. |  PESO | WEIGHT: 289 kg. |  CARGA DE PLACAS / PLATE LOADING: 104.42 + 2.27 (PC20-OPT) / 106.69 kg.





**PC2021**  
DUAL PECHO/HOMBROS  
DUAL CHEST PRESS/SHOULDER PRESS

 DIMENSIONES | DIMENSIONS: 135 x 198.4 x 150 cm. |  PESO | WEIGHT: 250 kg. |  CARGA DE PLACAS / PLATE LOADING: 108.86 + 2.27 (PC20-OPT) / 111.13 kg.





**PC2027**  
DUAL BÍCEPS/TRÍCEPS  
DUAL BICEPS CURL/TRICEPS EXTENSION

 DIMENSIONES | DIMENSIONS: 131.8 x 110.4 x 150 cm. |  PESO | WEIGHT: 178.5 kg. |  CARGA DE PLACAS / PLATE LOADING: 47.63 + 2.27 (PC20-OPT) / 50 kg.





**PC2033**  
DUAL POLEA BÍCEPS/TRÍCEPS  
DUAL BICEPS/TRICEPS PULLEY

 DIMENSIONES | DIMENSIONS: 70.9 x 149.2 x 210.4 cm. |  PESO | WEIGHT: 201 kg. |  CARGA DE PLACAS / PLATE LOADING: 104.42 + 2.27 (PC20-OPT) / 106.69 kg.





**PC2060**  
DUAL PECHO/HOMBRO DE PIE  
DUAL STANDING MULTI FLIGHT

 DIMENSIONES | DIMENSIONS: 150 x 93 x 200 cm. |  PESO | WEIGHT: 352 kg. |  CARGA DE PLACAS / PLATE LOADING: 100 kg.





**PC2012**  
DUAL VUELO HOMBRO/PECHO SENTADO  
DUAL MULTI FLIGHT / PEC SEATED

 DIMENSIONES | DIMENSIONS: 153 x 71 x 156.7 cm. |  PESO | WEIGHT: 205 kg. |  CARGA DE PLACAS / PLATE LOADING: 86.26 kg.





**PC2020**  
PATADA DE GLÚTEO  
KICK BACK GLUTE

 DIMENSIONES | DIMENSIONS: 216 x 100 x 150 cm. |
  PESO | WEIGHT: 218 kg. |
  CARGA DE PLACAS / PLATE LOADING: 77.18 + 2.27 (PC20-OPT) / 79.45 kg.





**PC2015**  
GLUTE DRIVE  
GLUTE DRIVE

 DIMENSIONES | DIMENSIONS: 162.4 x 117.2 x 149.6 cm. |
  PESO | WEIGHT: 245 kg. |
  CARGA DE PLACAS / PLATE LOADING: 104.42 + 2.27 (PC20-OPT) / 106.69 kg.





**PC2009**  
CONTRACCIÓN ABDOMINAL  
ABDOMINAL CRUNCH

 DIMENSIONES | DIMENSIONS: 90 x 121 x 150 cm. |
  PESO | WEIGHT: 216 kg. |
  CARGA DE PLACAS / PLATE LOADING: 86.2 kg.



**PC2010**  
CONTRACCIÓN LUMBAR  
BACK EXTENSION

 DIMENSIONES | DIMENSIONS: 122.3 x 121.9 x 150 cm. |
  PESO | WEIGHT: 219 kg. |
  CARGA DE PLACAS / PLATE LOADING: 86.2 kg.





DESCARGAR CATÁLOGO  
DOWNLOAD CATALOGUE

# EQUIPAMOS TU **BOX** Y **ZONA FUNCIONAL**

# AFW<sup>®</sup>

AllFreeWeight  
*EMPOWER YOUR WORKOUTS*

[www.allfreeweight.com](http://www.allfreeweight.com)



# SERIES

# PC60

La línea PC60 de Etenon Fitness cuenta con un rediseño evolucionado, elegante y estético, respaldado por un exhaustivo estudio de calidad biomecánica que garantiza un uso totalmente profesional. Con un diseño vanguardista y atractivo cuenta con una torre metálica de placas de peso que ayuda al desarrollo muscular mediante la tensión creada en el músculo a través de su sistema de poleas de PA con material autolubricante. Asegura un rendimiento superior y una durabilidad excepcional cumpliendo con la norma EN-957. La Serie PC60 cuenta con máquinas convergentes, unilaterales y duales

## CARACTERÍSTICAS TÉCNICAS

- Diseñadas a través de un exhaustivo estudio en biomecánica para un trabajo óptimo.
- Fabricada en tubo de acero oval de 3 mm de grosor: 150 x 50 x 3.0 mm.
- Brazos contrabalanceados que Anulan el peso de la parte de la estructura que hay que mover, para levantar sólo el peso seleccionado con las placas.
- Uso de sistema de levas para desarrollar un peso uniforme. Mantiene el brazo de fuerza con una resistencia constante durante todo el recorrido.
- Pintura polvo de poliéster anticorrosiva de color negro mate con gran calidad de acabado.
- Las placas son de acero calibrado, pintadas en negro.
- Incorpora selectores de aluminio magnéticos.
- Torre de placas con indicadores de peso en kg.
- Las barras guías son de acero inoxidable.
- Dispone de cables de transmisión de acero reforzados de 3 mm de grosor, sumamente flexibles y resistentes con funda protectora de 2 mm. La sensación y movimiento es siempre fluida.
- Tracción fluida. Dispone de poleas de PA con material autolubricante. Baja fricción y alta durabilidad.
- Carenados delantero y trasero metálico para evitar accidentes mientras las placas están en movimiento.
- Las poleas de transmisión incorporan rodamientos de bolas que garantizan un movimiento suave y silencioso.
- Ajuste del asiento, respaldo y rodillos acolchado para acomodar la posición de trabajo a las necesidades de cada usuario.
- Pomos anatómicos fabricados en aluminio para regulación de los puntos de apoyo o ajustes que garantizan una gran durabilidad.
- Cuenta con diversos soportes (botella, móvil y toalla).
- Tapizado de alta calidad, resistente al uso intensivo, antibacteriano e ignífugo.
- Agarres cómodos fabricados en goma no porosa y acabados con terminales en acero inoxidable. Ofrecen una muy buena sensación de agarre y seguridad al contacto.
- Incluye pictogramas explicativos para la correcta ejecución del ejercicio. (Posibilidad de incluir código QR con acceso a vídeo).
- Patas con protectores en goma.
- 7 años de garantía en la estructura.

The Etenon Fitness PC60 line has an evolved, elegant and aesthetic redesign, backed by an exhaustive study of biomechanical quality that guarantees totally professional use. With an avant-garde and attractive design which it has a metal tower of weight plates, helps muscle development through the tension created in the muscle through its PA pulley system with self-lubricating material. The PC60 ensures superior performance and exceptional durability, complying with the EN-957 standard. PC60 series includes convergent, unilateral and dual machines.

## TECHNICAL CHARACTERISTICS

- Designed through an exhaustive study in biomechanics for optimal work.
- Made of 3 mm thick oval steel tube: 150 x 50 x 3.0 mm.
- Counterbalanced arms which offset the weight of the part of the structure to be moved, so the user only lifts the weight selected with the plates.
- Use of cam system to develop uniform weight. Maintains the force arm with constant resistance throughout the entire movement.
- Matte black anticorrosive polyester powder paint with great quality finish.
- The plates are made of calibrated steel, painted black.
- Includes magnetic aluminum selectors.
- Plate tower with weight indicators in kg.
- The guide bars are made of stainless steel.
- It has 3 mm thick, highly flexible and resistant reinforced steel transmission cables with a 2 mm protective sheath. The sensation and movement is always fluid.
- Fluid traction. It has PA pulleys with self-lubricating material. Low friction and high durability.
- Metal front and rear fairings to avoid accidents while the plates are in motion.
- The transmission pulleys incorporate ball bearings that guarantee smooth and silent movement.
- Padded seat, backrest and roller adjustments to adapt the working position to the needs of each user.
- Anatomical knobs made of aluminum for regulating the support points or adjustments that guarantee great durability.
- It has various supports (bottle, mobile phone and towel).
- High quality upholstery, resistant to intensive use, antibacterial and fireproof.
- Comfortable grips made of non-porous rubber and finished with stainless steel terminals. They offer a very good feeling of grip and security upon contact.
- Includes explanatory pictograms for the correct execution of the exercise. (Possibility of including QR code with video access).
- Legs with rubber protectors.
- 7 years warranty on the structure.

**1** Brazos contrabalanceados.  
Counterbalanced arms.

**2** Barra guía de acero inoxidable.  
Stainless steel guide bar.

**3** Selector de placas magnético.  
Magnetic weight selector.

**4** Pictograma con la postura correcta para la realización del ejercicio y los músculos implicados.

Pictogram with the correct posture for the exercises, and which muscles are involved.

**5** Agarres de goma no absorbentes y antideslizantes.

Non-slip and non-absorbent rubber grips.

**6** Tapizado con espuma y polipiel ignífuga.

Upholstery with foam rubber fireproof leatherette.

**7** Carenado protector para evitar accidentes mientras las placas están en movimiento.

Protective fairing to avoid accidents while the plates are in movement.

**8** Regulación mediante sistema de palanca fácil.

Regulation by easy lever system.

**9** Botellero, soporte para móvil y toalla.

Bottle rack, mobile phone holder and towel holder.





**PC6010**  
EXTENSIÓN DE CUÁDRICEPS  
LEG EXTENSION

DIMENSIONES | DIMENSIONS: 120.6 x 112 x 154.5 cm. | PESO | WEIGHT: 195 kg. | CARGA DE PLACAS / PLATE LOADING: 100 kg.



**PC6012**  
FEMORAL TUMBADO  
LYING LEG CURL

DIMENSIONES | DIMENSIONS: 159.5 x 110 x 154.5 cm. | PESO | WEIGHT: 236 kg. | CARGA DE PLACAS / PLATE LOADING: 100 kg.



**PC6009**  
PRENSA SENTADO  
SEATED LEG PRESS

DIMENSIONES | DIMENSIONS: 177 x 116 x 154.5 cm. | PESO | WEIGHT: 257 kg. | CARGA DE PLACAS / PLATE LOADING: 90 kg.



**PC6015**  
PATADA DE GLÚTEO  
KICK BACK GLUTE

DIMENSIONES | DIMENSIONS: 97 x 90 x 154.5 cm. | PESO | WEIGHT: 160 kg. | CARGA DE PLACAS / PLATE LOADING: 60 kg.



**PC6008**  
FONDOS DE TRÍCEPS  
TRICEPS PRESS

DIMENSIONES | DIMENSIONS: 119.5 x 113 x 154.5 cm. | PESO | WEIGHT: 208 kg. | CARGA DE PLACAS / PLATE LOADING: 90 kg.



**PC6002**  
APERTURAS PECTORAL  
PEC FLY

DIMENSIONES | DIMENSIONS: 135 x 138 x 154.5 cm. | PESO | WEIGHT: 232 kg. | CARGA DE PLACAS / PLATE LOADING: 90 kg.



**PC6001**  
PRESS VERTICAL CONVERGENTE  
CHEST PRESS

DIMENSIONES | DIMENSIONS: 147 x 134.5 x 154.5 cm. | PESO | WEIGHT: 232 kg. | CARGA DE PLACAS / PLATE LOADING: 90 kg.



**PC6004**  
PRESS DE HOMBROS CONVERGENTE  
SHOULDER PRESS

DIMENSIONES | DIMENSIONS: 156 x 135 x 154.5 cm. | PESO | WEIGHT: 237 kg. | CARGA DE PLACAS / PLATE LOADING: 90 kg.



**PC6003**  
REMO SENTADO CONVERGENTE  
SEATED ROWING

DIMENSIONES | DIMENSIONS: 150.5 x 116 x 154.5 cm. | PESO | WEIGHT: 225 kg. | CARGA DE PLACAS / PLATE LOADING: 90 kg.



**PC6006**  
JALÓN DORSAL  
LAT PULLDOWN

DIMENSIONES | DIMENSIONS: 141 x 132 x 188 cm. | PESO | WEIGHT: 230 kg. | CARGA DE PLACAS / PLATE LOADING: 90 kg.



**PC6017**  
CONTRACCIÓN LUMBAR  
BACK EXTENSION

DIMENSIONES | DIMENSIONS: 146 x 98.5 x 154.5 cm. | PESO | WEIGHT: 206 kg. | CARGA DE PLACAS / PLATE LOADING: 90 kg.



**PC6016**  
CONTRACCIÓN ABDOMINAL  
ABDOMINAL CRUNCH

DIMENSIONES | DIMENSIONS: 144 x 105 x 168.8 cm. | PESO | WEIGHT: 275 kg. | CARGA DE PLACAS / PLATE LOADING: 90 kg.



**PC6023**  
**DUAL QUÁDRICEPS/FEMORAL SENTADO**  
 DUAL QUADRICEPS/SEATED LEG CURL

DIMENSIONES | DIMENSIONS: 130 x 109 x 154.5 cm. | 
 PESO | WEIGHT: 251 kg. | 
 CARGA DE PLACAS / PLATE LOADING: 100 kg.



**PC6019**  
**DUAL ABDUCTOR / ADDUCTOR**  
 DUAL ABDUCTION/ADDUCTION

DIMENSIONES | DIMENSIONS: 132.5 x 133 x 154.5 cm. | 
 PESO | WEIGHT: 228 kg. | 
 CARGA DE PLACAS / PLATE LOADING: 90 kg.



**PC6013**  
**DUAL APERTURAS /DELTOIDES**  
 DUAL PEC FLY/REAR DELTOID

DIMENSIONES | DIMENSIONS: 121 x 94 x 204.5 cm. | 
 PESO | WEIGHT: 240 kg. | 
 CARGA DE PLACAS / PLATE LOADING: 100 kg.



**PC6024**  
**DUAL PRESS PECHO/HOMBROS**  
 DUAL CHEST PRESS/SHOULDER PRESS

DIMENSIONES | DIMENSIONS: 187.2 x 126 x 154.5 cm. | 
 PESO | WEIGHT: 235 kg. | 
 CARGA DE PLACAS / PLATE LOADING: 90 kg.



**PC6007**  
**CURL DE BÍCEPS ALTERNO**  
 BICEPS CURL

DIMENSIONES | DIMENSIONS: 145.7 x 122 x 154.5 cm. | 
 PESO | WEIGHT: 188 kg. | 
 CARGA DE PLACAS / PLATE LOADING: 60 kg.



**PC6068**  
**REMO BAJO**  
 LOW ROW

DIMENSIONES | DIMENSIONS: 183 x 109 x 177 cm. | 
 PESO | WEIGHT: 225 kg. | 
 CARGA DE PLACAS / PLATE LOADING: 120 kg.





**PC6091**  
**DUAL POLEA ALTA/BAJA**  
 DUAL HIGH PULL/LOW ROW

**DIMENSIONES | DIMENSIONS:** 152 x 82.3 x 224.7 cm. |
 **PESO | WEIGHT:** 220 kg. |
 **CARGA DE PLACAS / PLATE LOADING:** 110 kg.



**PC6051**  
**DUAL DOMINADAS/FONDOS ASISTIDOS**  
 DUAL ASSIST DIP CHIP

**DIMENSIONES | DIMENSIONS:** 93.5 x 142.5 x 237.5 cm. |
 **PESO | WEIGHT:** 300 kg. |
 **CARGA DE PLACAS / PLATE LOADING:** 135 kg.



**PC6022**  
**DUAL BÍCEPS /TRÍCEPS**  
 DUAL BICEPS/TRICEPS

**DIMENSIONES | DIMENSIONS:** 138 x 102 x 154.5 cm. |
 **PESO | WEIGHT:** 190 kg. |
 **CARGA DE PLACAS / PLATE LOADING:** 60 kg.



**PC6018**  
**ROTACIÓN DE TORSO**  
 TORSO ROTATION

**DIMENSIONES | DIMENSIONS:** 153 x 134 x 154.5 cm. |
 **PESO | WEIGHT:** 190 kg. |
 **CARGA DE PLACAS / PLATE LOADING:** 80 kg.



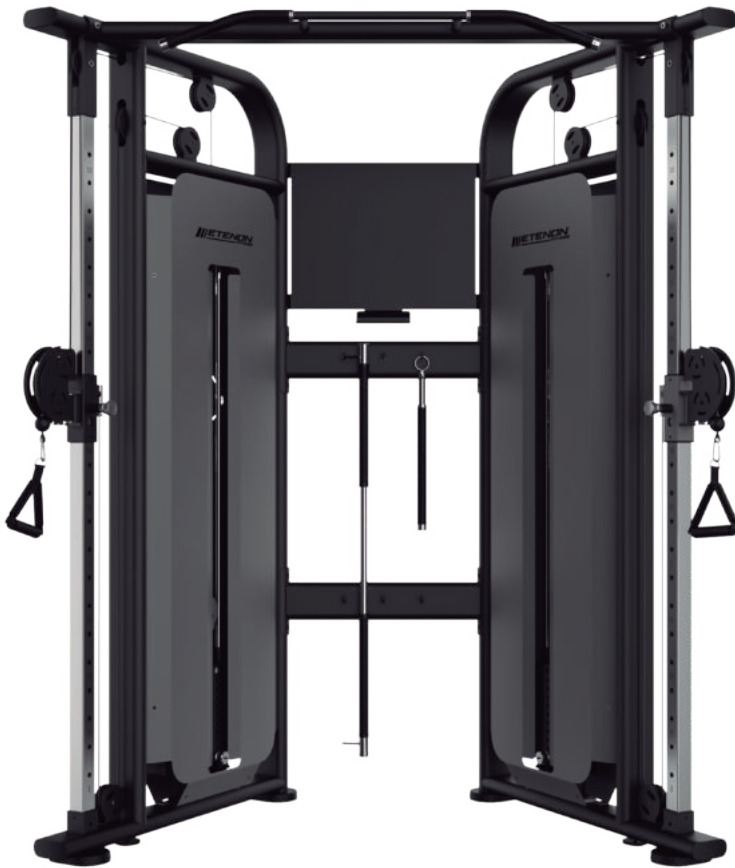

## PC6020

### DUAL FUNCIONAL TRAINER

DUAL FUNCIONAL TRAINER

- Diseñadas a través de un exhaustivo estudio en biomecánica para un trabajo óptimo.
  - Fabricada en tubo de acero: 120 x 50 x 3.0 mm.
  - Pintura polvo de poliéster anticorrosiva de color negro mate con gran calidad de acabado.
  - Dispone de cables de transmisión de acero reforzados de 3 mm de grosor, sumamente flexibles y resistentes con funda protectora de 2 mm. La sensación y movimiento es siempre fluida.
  - Las poleas de transmisión incorporan rodamientos de bolas que garantizan un movimiento suave y silencioso.
  - La estructura de la línea PC60 cuenta con soldaduras reforzadas.
  - Tracción fluida. Dispone de poleas de PA con material autolubrificante. Baja fricción y alta durabilidad.
  - Incluye pictogramas explicativos para la correcta ejecución del ejercicio. (Posibilidad de incluir código QR con acceso a vídeo).
  - Incorpora selectores de aluminio magnéticos con alta durabilidad y muy estéticos.
  - Agarres cómodos fabricados en goma no porosa. Ofrecen una muy buena sensación de agarre y seguridad al contacto.
  - Las barras guías son de acero inoxidable.
  - Regulación en altura de ambas poleas.
  - Patas con protectores en goma.
  - Carenados delantero y trasero metálico para evitar accidentes mientras las placas están en movimiento.
  - Torre de placas con indicadores de peso en kg.
- Designed through an exhaustive study in biomechanics for optimal work.
  - Made of steel tube: 120 x 50 x 3.0 mm.
  - Anti-corrosive polyester powder paint in matt black with a high quality finish.
  - It has 3 mm thick reinforced steel transmission cables, extremely flexible and resistant with a 2 mm protective sheath. The feel and movement is always smooth.
  - The drive pulleys are fitted with ball bearings to ensure smooth and quiet movement.
  - The structure of the PC60 line has reinforced welds.
  - Smooth traction. PA pulleys with self-lubricating material. Low friction and high durability.
  - Includes explanatory pictograms for the correct execution of the exercise (possibility of including QR code with access to video).
  - Includes highly durable and aesthetic magnetic aluminium selectors.
  - Comfortable grips made of non-porous rubber. They offer a very good feeling of grip and safety on contact.
  - The guide rods are made of stainless steel.
  - Height adjustment of both pulleys.
  - Legs with rubber protectors.
  - Metal front and rear fairings to prevent accidents while the plates are in motion.
  - It incorporates magnetic aluminum selectors with high durability and very aesthetic.
  - Regulation of both hanging pulleys.
  - Legs with PVC protectors.
  - Front and rear fairings to avoid accidents while the plates are in motion.
  - Plate tower with weight indicators in kg.



DIMENSIONES | DIMENSIONS:  
94 x 166 x 224 cm.



PESO | WEIGHT:  
405 kg.



CARGA DE PLACAS / PLATE LOADING:  
200 kg. (100 kg. x 2)

## PC6052

### CRUCE DE POLEAS

PULLEY CROSSING

- Diseñadas a través de un exhaustivo estudio en biomecánica para un trabajo óptimo.
  - Fabricada en tubo de acero oval de 3 mm de grosor: 150 x 50 x 3.0 mm.
  - Pintura polvo de poliéster anticorrosiva de color negro mate con gran calidad de acabado.
  - Dispone de cables de transmisión de acero reforzados de 3 mm de grosor, sumamente flexibles y resistentes con funda protectora de 2 mm. La sensación y movimiento es siempre fluida.
  - Las poleas de transmisión incorporan rodamientos de bolas que garantizan un movimiento suave y silencioso.
  - Incorpora selectores de aluminio magnéticos con alta durabilidad y muy estéticos.
  - Agarres cómodos fabricados en goma. Ofrecen una muy buena sensación de agarre al contacto.
  - Tracción fluida. Dispone de poleas de PA con material autolubrificante. Baja fricción y alta durabilidad.
  - Las barras guías son de acero inoxidable (cromoduro) ajustables verticalmente.
  - Torre de placas con indicadores de peso en kg.
  - Barra de dominadas multiagarre.
  - Patas con protectores en goma.
- Designed through an exhaustive study in biomechanics for optimal work.
  - Made of 3 mm thick oval steel tube: 150 x 50 x 3.0 mm.
  - Anti-corrosive polyester powder paint in matt black with a high quality finish.
  - It has 3 mm thick reinforced steel transmission cables, extremely flexible and resistant with a 2 mm protective sheath. The feel and movement is always smooth.
  - The drive pulleys are fitted with ball bearings to ensure smooth and quiet movement.
  - The aluminium magnetic selectors are highly durable and aesthetically pleasing.
  - Comfortable rubber grips. They offer a very good feeling of grip on contact.
  - Smooth traction. PA pulleys with self-lubricating material. Low friction and high durability.
  - Vertically adjustable stainless steel (chrome-plated) guide rods.
  - Plate tower with weight indicators in kg.
  - Multi-grip pull-up bar.
  - Legs with rubber protectors.



DIMENSIONES | DIMENSIONS:  
377.5 x 92.5 x 229 cm.



PESO | WEIGHT:  
340 kg.



CARGA DE PLACAS / PLATE LOADING:  
180 kg. (90 kg. x 2)





# SERIES M5

La línea M5 está formada por una amplia variedad de máquinas selectorizadas unilaterales, convergentes o duales fabricadas para uso profesional.

Se caracterizan por tener un diseño elegante y funcional. Han sido ergonómicamente diseñadas para proporcionar un movimiento natural y maximizar la efectividad de los ejercicios. Cumplen con la norma EN-957 Clase S.

## CARACTERÍSTICAS TÉCNICAS

- Estructura construida en tubo oval de acero de alta calidad de 3 mm. de espesor.
- Partes desmontables de acero macizo con el que se evitan problemas de desgaste.
- Las máquinas están montadas sobre rodamientos (circulares o lineales) o ruedas de bronce y rodamientos.
- Contrapeso de acero resistente de alta calidad.
- Poleas con rodamientos que aseguran un movimiento fluido.
- El proceso de pintado de las máquinas se realiza en túnel de tratamiento de dos capas.
- Las placas son de acero calibrado de alta calidad laminadas en caliente, cortadas al láser y resistentes a la corrosión. Incluyen casquillos para evitar fricciones y ruido durante el ejercicio.
- Pasador de selección de placas en acero inoxidable con cabezal imantado para evitar que el selector se salga durante el ejercicio.
- Las barras guías son de acero inoxidable con tratamiento a alta temperatura.
- Dispone de cables de transmisión de acero reforzados de 4 mm de grosor y funda protectora de 2 mm, sumamente flexibles y resistentes. La sensación y movimiento es siempre fluida.
- Carenado protector en la torre de placas para evitar posibles accidentes mientras las placas están en movimiento.
- Las máquinas incorporan múltiples ajustes y regulaciones para acomodar la posición de trabajo a las necesidades de cada usuario.
- Tapizado realizado en goma espuma de 3 cm. de espesor con 150 kg. de presión, y polipiel ignífuga.
- Agarres de PVC impermeable con forma anatómica.
- Incluyen botellero y soporte para toalla.
- Pictogramas explicativos sobre la postura correcta para la realización del ejercicio y los músculos implicados en el mismo.
- Patas con protectores en PVC.
- Garantía en la estructura de 7 años.

The M5 line is a wide variety of unilateral, convergent or dual selectorized machines made for professional use. They have an elegant and functional design. They have been ergonomically designed to provide natural movement and maximize the effectiveness of the exercises. They comply with the EN-957 Class S.

## TECHNICAL CHARACTERISTICS

- Structure built in high quality 3 mm oval steel tube of thickness.
- Removable parts made of solid steel to avoid wear problems.
- The machines are mounted on bearings (circular or linear) or bronze wheels and bearings.
- High quality heavy duty steel counterweight.
- Pulleys with bearings that ensure fluid movement.
- The painting process of the machines is carried out in a two-layer treatment tunnel.
- The plates are high quality calibrated steel, hot rolled, laser cut and corrosion resistant. They include bushings to avoid friction and noise during exercise.
- Stainless steel plate selection pin with magnetic head to prevent the selector coming off during exercise.
- The guide bars are made of stainless steel with high temperature treatment.
- It has 4 mm thick reinforced steel transmission cables and a 2 mm protective sheath, extremely flexible and resistant. The sensation and movement is always fluid.
- Protective fairing on the plate tower to avoid possible accidents while the plates are in motion.
- The machines incorporate multiple adjustments and regulations to adapt the working position to the needs of each user.
- Upholstered in 3 cm foam rubber. thick with 150 kg. pressure, and fireproof leatherette.
- Anatomically shaped waterproof PVC grips.
- They include a bottle rack and towel holder.
- Explanatory pictograms on the correct posture to perform the exercise and the muscles involved in it.
- Legs with PVC protectors.
- 7-year structure warranty.

**1** Contrapeso.  
Counterbalance.

**2** Botellero y soporte para toalla.  
Bottle rack and towel holder.

**3** Barra guía de acero inoxidable.  
Stainless steel guide bar.

**4** Pictograma con la postura correcta para la realización del ejercicio y los músculos implicados.  
Pictogram with the correct posture for the exercises, and which muscles are involved.

**5** Agarres de PVC  
PVC grips.

**6** Tapizado con espuma y polipiel ignífuga.  
Upholstery with foam rubber fireproof leatherette.

**7** Carenado protector para evitar accidentes mientras las placas están en movimiento.  
Protective fairing to avoid accidents while the plates are in movement.

**8** Regulación mediante sistema de palanca fácil.  
Regulation by easy lever system.

**9** Selector de placas magnético.  
Magnetic weight selector.





**M5014**  
EXTENSIÓN DE CUÁDRICEPS  
LEG EXTENSION

DIMENSIONES | DIMENSIONS: 119 x 179 x 153.5 cm. |
 PESO | WEIGHT: 265 kg. |
 CARGA DE PLACAS / PLATE LOADING: 100 kg.



**M5024**  
DUAL CUÁDRICEPS/FEMORAL SENTADO  
DUAL QUADRICEPS/SEATED LEG CURL

DIMENSIONES | DIMENSIONS: 120 x 140 x 153.5 cm. |
 PESO | WEIGHT: 290 kg. |
 CARGA DE PLACAS / PLATE LOADING: 100 kg.



**M5013A**  
FEMORAL TUMBADO  
LYING LEG CURL

DIMENSIONES | DIMENSIONS: 116.5 x 170 x 153.5 cm. |
 PESO | WEIGHT: 266 kg. |
 CARGA DE PLACAS / PLATE LOADING: 100 kg.



**M5013**  
FEMORAL SENTADO  
SEATED LEG CURL

DIMENSIONES | DIMENSIONS: 124 x 177 x 153.5 cm. |
 PESO | WEIGHT: 269 kg. |
 CARGA DE PLACAS / PLATE LOADING: 100 kg.



**M5015**  
PRENSA SENTADO  
LEG PRESS

DIMENSIONES | DIMENSIONS: 115 x 204.5 x 153.5 cm. |
 PESO | WEIGHT: 291 kg. |
 CARGA DE PLACAS / PLATE LOADING: 100 kg.



**M5025**  
DUAL ABDUCTOR/ADDUCTOR  
DUAL ABDUCTOR/ADDUCTOR

DIMENSIONES | DIMENSIONS: 160 x 100 x 153.5 cm. |
 PESO | WEIGHT: 260 kg. |
 CARGA DE PLACAS / PLATE LOADING: 100 kg.



**M5016**  
MULTICADERA  
MULTIHIP

DIMENSIONES | DIMENSIONS: 108.5 x 105.5 x 158 cm. | PESO | WEIGHT: 241 kg. | CARGA DE PLACAS / PLATE LOADING: 100 kg.



**M5016A**  
PATADA DE GLÚTEO  
GLUTE KICK BACK

DIMENSIONES | DIMENSIONS: 100 x 135.5 x 153.5 cm. | PESO | WEIGHT: 229 kg. | CARGA DE PLACAS / PLATE LOADING: 100 kg.



**M5017**  
PRENSA DE GEMELO  
CALF EXTENSION

DIMENSIONES | DIMENSIONS: 107.5 x 161.5 x 153.5 cm. | PESO | WEIGHT: 270 kg. | CARGA DE PLACAS / PLATE LOADING: 100 kg.



**M5023**  
DUAL ABDOMINAL /LUMBAR  
DUAL ABDOMINAL CRUNCH/BACK EXTENSION

DIMENSIONES | DIMENSIONS: 125 x 125 x 153.5 cm. | PESO | WEIGHT: 240 kg. | CARGA DE PLACAS / PLATE LOADING: 100 kg.



**M5021**  
DUAL POLEA ALTA/BAJA  
DUAL HIGH PULLEY/ROW

DIMENSIONES | DIMENSIONS: 152 x 190 x 210 cm. | PESO | WEIGHT: 275 kg. | CARGA DE PLACAS / PLATE LOADING: 100 kg.



**M5008**  
DUAL DOMINADAS/FONDOS ASISTIDOS  
DUAL ASSISTED CHIN/DIP

DIMENSIONES | DIMENSIONS: 145.5 x 127.5 x 233.5 cm. | PESO | WEIGHT: 319 kg. | CARGA DE PLACAS / PLATE LOADING: 100 kg.



**M5001**  
PRESS VERTICAL  
CHEST PRESS

DIMENSIONES | DIMENSIONS: 143.5 x 144.5 x 153.5 cm. | PESO | WEIGHT: 263 kg. | CARGA DE PLACAS / PLATE LOADING: 100 kg.



**M5020**  
DUAL PRESS PECHO/HOMBRO  
DUAL SHOULDER/PECTORAL PRESS

DIMENSIONES | DIMENSIONS: 146 x 195 x 153.5 cm. | PESO | WEIGHT: 260 kg. | CARGA DE PLACAS / PLATE LOADING: 100 kg.



**M5002A**  
DUAL APERTURAS/DELTOIDES  
DUAL PEC FLY/REAR DELT

DIMENSIONES | DIMENSIONS: 150.5 x 121.5 x 200 cm. | PESO | WEIGHT: 262 kg. | CARGA DE PLACAS / PLATE LOADING: 100 kg.



**M5002**  
CONTRACTORA  
PEC DECK

DIMENSIONES | DIMENSIONS: 148 x 123.5 x 153.5 cm. | PESO | WEIGHT: 275 kg. | CARGA DE PLACAS / PLATE LOADING: 100 kg.



**M5003**  
PRESS DE HOMBROS  
SHOULDER PRESS

DIMENSIONES | DIMENSIONS: 157.5 x 156.5 x 153.5 cm. | PESO | WEIGHT: 267 kg. | CARGA DE PLACAS / PLATE LOADING: 100 kg.



**M5004**  
REMO SENTADO  
SEATED ROW

DIMENSIONES | DIMENSIONS: 103.5 x 155.5 x 153.5 cm. | PESO | WEIGHT: 258 kg. | CARGA DE PLACAS / PLATE LOADING: 100 kg.







## M5022

### DUAL BÍCEPS/TRÍCEPS

DUAL BICEPS/TRICEPS



 DIMENSIONES | DIMENSIONS: 125 x 125 x 153.5 cm.
  PESO | WEIGHT: 235 kg.
  CARGA DE PLACAS / PLATE LOADING: 100 kg.



## M5007

### FONDOS DE TRÍCEPS

TRICEPS PRESS



 DIMENSIONES | DIMENSIONS: 125.5 x 151.5 x 153.5 cm.
  PESO | WEIGHT: 265 kg.
  CARGA DE PLACAS / PLATE LOADING: 100 kg.



## M5012

### JALÓN DORSAL

LAT PULLDOWN

 DIMENSIONES | DIMENSIONS: 146.5 x 179.5 x 200.5 cm.
  PESO | WEIGHT: 275 kg.
  CARGA DE PLACAS / PLATE LOADING: 100 kg.



# SPECIAL SERIES PC50

La línea PC50 revoluciona el entrenamiento al combinar la versatilidad de placas selectorizadas con la potencia de las máquinas de palanca o plate load. Sus diseños convergente, unilaterales o duales permiten trabajar cada grupo muscular con libertad y precisión, adaptable a todos los niveles, desde principiantes hasta profesionales. Con un diseño ergonómico que garantiza movimientos suaves y cómodos, la PC50 maximiza la experiencia de ejercicio gracias a sus ángulos precisos. Fabricada con acero de alta calidad y técnicas de corte y soldadura especializadas, la PC50 asegura un rendimiento superior y una durabilidad excepcional cumpliendo con la norma EN-957.

## CARACTERÍSTICAS TÉCNICAS

- Modelo único que ofrece la combinación de placas selectorizadas y carga de discos.
- Estructura construida en tubo oval de acero de alta calidad de 3 mm de espesor. 125 x 75 x 3.0 mm / 120 x 50 x 3.0 mm.
- Brazos contrabalanceados. Anulan el peso de la parte de la estructura que hay que mover, para levantar sólo el peso seleccionado con las placas de acero calibrado.
- Pintura polvo de poliéster anticorrosiva de color negro mate con gran calidad de acabado.
- Selector de placas magnético.
- Torre de placas con indicadores de peso en kg.
- Las barras guías son de acero inoxidable.
- Dispone de cables de transmisión de acero reforzados de 5 mm de grosor, sumamente flexibles y resistentes. La sensación y movimiento es siempre fluida.
- Carenados delantero y trasero para evitar accidentes mientras las placas están en movimiento.
- Sistema de carga de discos de peso mediante soportes en acero inoxidable.
- Las máquinas incorporan múltiples ajustes y regulaciones para acomodar la posición de trabajo a las necesidades de cada usuario.
- Ajustes con regulación hidráulica mediante sistema de palanca fácil.
- Agarres cómodos fabricados en goma no porosa y acabados con terminales en acero inoxidable. Ofrecen una muy buena sensación de agarre y seguridad al contacto.
- Tapizado de alta calidad, resistente al uso intensivo, antibacteriano e ignífugo.
- Incluye pictogramas explicativos para la correcta ejecución del ejercicio.
- Patas con protectores en PVC.
- Certificación ISO9001 y EN957.
- 7 años de garantía en la estructura.

The PC50 line revolutionizes training by combining the versatility of selectorized plates with the power of lever or plate load machines. Its convergent design allows each muscle group to be worked with freedom and precision, adaptable to all levels, from beginners to professionals. With an ergonomic design that ensures smooth and comfortable movements, the PC50 maximizes the exercise experience thanks to its precise angles. Manufactured with high quality steel and specialized cutting and welding techniques, the PC50 ensures superior performance and exceptional durability complying with the EN-957 standard.

## TECHNICAL CHARACTERISTICS

- Unique model that offers the combination of selector plates and disc loading.
- Structure built in high quality 3 mm thick oval steel tube. 125 x 75 x 3.0mm / 120 x 50 x 3.0 mm.
- Counterbalanced arms which offset the weight of the part of the structure to be moved, so the user only lifts the weight selected with the calibrated steel plates.
- Matte black anticorrosive polyester powder paint with high quality finish.
- Magnetic plate selector.
- Plate tower with weight indicators in kg.
- Stainless steel guide bars.
- It has 5 mm thick reinforced steel transmission cables, extremely flexible and resistant. The sensation and movement is always fluid.
- Front and rear fairings to avoid accidents while the plates are in motion.
- Plate loading system using stainless steel supports.
- The machines incorporate multiple adjustments and regulations to adapt the working position to the needs of each user.
- Hydraulic regulation adjustments through an easy lever system.
- Comfortable grips made of non-porous rubber and finished with stainless steel terminals. They offer a very good feeling of grip and security upon contact.
- High quality upholstery, resistant to intensive use, antibacterial and fire retardant.
- Includes explanatory pictograms for the correct execution of the exercise.
- Legs with PVC protectors.
- ISO9001 and EN957 certification.
- 7 years warranty on the structure.

**1** Brazos contrabalanceados.  
Counterbalanced arms.

**2** Barra guía de acero inoxidable.  
Stainless steel guide bar.

**3** Selector de placas magnético.  
Magnetic weight selector.

**4** Pictograma con la postura correcta para la realización del ejercicio y los músculos implicados.

Pictogram with the correct posture for the exercises, and which muscles are involved.

**5** Agarres de goma no absorbentes y antideslizantes.  
Non-slip and non-absorbent rubber grips.

**6** Tapizado con espuma y polipiel ignífuga.

Upholstery with foam rubber fireproof leatherette.

**7** Carenado protector para evitar accidentes mientras las placas están en movimiento.

Protective fairing to avoid accidents while the plates are in movement.

**8** Regulación hidráulica mediante sistema de palanca fácil.

Hydraulic regulation by means of an easy lever system.

**9** Combinación de placas selectorizadas y carga de placas.

Combination of selectorised plates and plate loading.







## PC5008

### EXTENSIÓN DE CUÁDRICEPS

LEG EXTENSION

 **DIMENSIONES | DIMENSIONS:**  
160 x 103 x 148 cm.

 **PESO | WEIGHT:**  
260 kg.

 **CARGA MAX. DISCOS | MAX DISC LOAD:**  
200 kg.

 **CARGA DE PLACAS / PLATE LOADING:**  
100 kg.





## PC5009

### FEMORAL TUMBADO

LYING LEG CURL

 **DIMENSIONES | DIMENSIONS:**  
167 x 129.5 x 148 cm.

 **PESO | WEIGHT:**  
238 kg.

 **CARGA MAX. DISCOS | MAX DISC LOAD:**  
200 kg.

 **CARGA DE PLACAS / PLATE LOADING:**  
100 kg.





## PC5007

### PRENSA SENTADO

SEATED LEG PRESS

 **DIMENSIONES | DIMENSIONS:**  
152.5 x 168 x 148 cm.

 **PESO | WEIGHT:**  
385 kg.

 **CARGA MAX. DISCOS | MAX DISC LOAD:**  
200 kg.

 **CARGA DE PLACAS / PLATE LOADING:**  
90 kg.





## PC5010

### PATADA DE GLÚTEO

GLUTE KICK BACK

 **DIMENSIONES | DIMENSIONS:**  
135 x 103 x 148 cm.

 **PESO | WEIGHT:**  
260 kg.

 **CARGA MAX. DISCOS | MAX DISC LOAD:**  
200 kg.

 **CARGA DE PLACAS / PLATE LOADING:**  
80 kg.





## PC5003

### POLEA ALTA CONVERGENTE

LAT PULL DOWN

 **DIMENSIONES | DIMENSIONS:**  
152.5 x 142 x 198 cm.

 **PESO | WEIGHT:**  
275 kg.

 **CARGA MAX. DISCOS | MAX DISC LOAD:**  
200 kg.

 **CARGA DE PLACAS / PLATE LOADING:**  
100 kg.





## PC5004

### POLEA ALTA INVERTIDA CONVERGENTE

FRONT LAT PULL DOWN

 **DIMENSIONES | DIMENSIONS:**  
149.5 x 142.5 x 193 cm.

 **PESO | WEIGHT:**  
284 kg.

 **CARGA MAX. DISCOS | MAX DISC LOAD:**  
200 kg.

 **CARGA DE PLACAS / PLATE LOADING:**  
100 kg.





## PC5001

### PRESS VERTICAL CONVERGENTE

CONVERGENT CHEST PRESS

 DIMENSIONES | DIMENSIONS:  
169 x 182.5 x 174 cm.

 PESO | WEIGHT:  
325 kg.

 CARGA MAX. DISCOS | MAX DISC LOAD:  
200 kg.

 CARGA DE PLACAS / PLATE LOADING:  
100 kg.





## PC5002

### APERTURAS INCLINADAS

INCLINE PEC FLY

 DIMENSIONES | DIMENSIONS:  
180 x 195 x 148 cm.

 PESO | WEIGHT:  
285 kg.

 CARGA MAX. DISCOS | MAX DISC LOAD:  
200 kg.

 CARGA DE PLACAS / PLATE LOADING:  
80 kg.





## PC5005

### PRESS DE HOMBROS CONVERGENTE

CONVERGENT SHOULDER PRESS

 DIMENSIONES | DIMENSIONS:  
189.5 x 163.5 x 148 cm.

 PESO | WEIGHT:  
300 kg.

 CARGA MAX. DISCOS | MAX DISC LOAD:  
200 kg.

 CARGA DE PLACAS / PLATE LOADING:  
80 kg.





## PC5006

### ELEVACIONES LATERALES

LATERAL RAISE

 DIMENSIONES | DIMENSIONS:  
120 x 151 x 148 cm.

 PESO | WEIGHT:  
205 kg.

 CARGA MAX. DISCOS | MAX DISC LOAD:  
200 kg.

 CARGA DE PLACAS / PLATE LOADING:  
80 kg.



# SPECIAL SERIES PC70

Etenon Fitness incorpora su nueva serie PC70, una revolucionaria línea de maquinaria de fuerza que presenta como novedad su innovadora tecnología Bio-Arc. Este desarrollo tecnológico muestra al mercado del fitness las primeras máquinas de carga de placas que incorporan un movimiento multiplanar del asiento en cada máquina a lo largo de una trayectoria de arco lineal. El movimiento del asiento permite al usuario moverse a lo largo de la trayectoria del arco junto con la máquina, ayudando a mantener una longitud muscular más óptima y mejorando la fuerza de contracción y el estímulo del entrenamiento.

## CARACTERÍSTICAS TÉCNICAS

- Fabricada en tubo de acero Q235: 3.0 mm.
- Tubo redondo de acero de 120 de calibre 11 de 3" y 4-1/2" con una combinación de acero tubular de 120 de calibre 11 de 2x4".
- Acero macizo de 3/4" con acabado en cromo duro altamente pulido.
- Soldadura MIG con gas inerte que cumple con todos los estándares y especificaciones de acero del código de soldadura estructural.
- Mecánica óptima para la activación muscular. El cuerpo del usuario se mueve a lo largo de una trayectoria de arco lineal para optimizar el reclutamiento muscular.
- El usuario levanta el peso de las placas más su propio peso corporal al realizar el ejercicio.
- Placas de acero pintadas de negro de 3/4" con ruido reducido y manguitos autoalineantes de baja fricción. El peso levantado es el peso combinado aproximado del usuario y el peso seleccionado.
- Polea de nailon reforzado con fibra de vidrio de 4-1/2", 3-1/2" y 2".
- Cable de fitness de alto rendimiento de 3/16".
- Pasadores de acero sólido con resorte de vaivén de 1/2" con carga máxima de 4100 kg.
- La liberación del gatillo permite un fácil ajuste de la almohadilla para el pie a la posición inicial deseada.
- Relleno de PU moldeada pegada a un respaldo de madera contrachapada industrial de 1", combinada con tapicería premium de doble costura.
- Tapizados: Vinilo Bolta Sport premium con PreFixx, formulado para resistir bacterias, manchas, moho, aceite y pigmentos estabilizados contra los rayos UV. Cumple con la mayoría de los requisitos de pruebas de inflamabilidad.
- Patas con protectores en PVC.
- Garantía estructura: 7 años.

Etenon Fitness incorporates its new PC70 series, a revolutionary line of strength machinery that presents its innovative Bio-Arc technology as a novelty. This technological development shows the fitness market the first plate loading machines that incorporate multiplanar seat movement in each machine along a linear arc path. The seat movement allows the user to move along the arc path along with the machine, helping to maintain more optimal muscle length and improving contraction strength and training stimulus.

## TECHNICAL CHARACTERISTICS

- Made of Q235 steel tubing: 3.0 mm.
- 3" and 4-1/2" 11 gauge 120 round steel tubing with a combination of 2x4" 11 gauge 120 tubular steel.
- 3/4" solid steel with highly polished hard chrome finish.
- Inert gas MIG welded to meet all structural welding code steel standards and specifications.
- Optimal mechanics for muscle activation. The user's body moves along a linear arc path to optimise muscle recruitment.
- The user lifts the weight of the plates plus his own body weight during the exercise.
- 3/4" black painted steel plates with reduced noise and low friction self-aligning sleeves. Lifted weight is the approximate combined weight of the user and the selected weight.
- 4-1/2", 3-1/2" and 2" fibreglass reinforced nylon pulley blocks.
- 3/16" heavy duty fitness cable.
- 1/2" solid steel pins with 1/2" swing spring with 4100 kg maximum load.
- Trigger release allows easy adjustment of the foot pad to the desired starting position.
- Moulded PU padding bonded to a 1" industrial plywood backing, combined with premium double-stitched upholstery.
- Upholstery: Bolta Sport premium vinyl with PreFixx, formulated to resist bacteria, stains, mildew, oil and UV stabilised pigments. Meets most flammability testing requirements.
- Feet with PVC protectors.
- Structure guarantee: 7 years.

**1** Sistema Bio-Arc.  
Bio-Arc system.

**2** Barra guía de acero inoxidable.  
Stainless steel guide bar.

**3** Botellero y portaobjetos en la parte superior.  
Bottle and personal items holder.

**4** Pictograma con la postura correcta para la realización del ejercicio y los músculos implicados.

Pictogram with the correct posture for the exercises, and which muscles are involved.

**5** Agarres de goma no absorbentes y antideslizantes.  
Non-slip and non-absorbent rubber grips.

**6** Tapizado Vinilo Bolta Sport premium con PreFixx con relleno de PU.

Upholstery Bolta Sport premium vinyl with PreFixx with PU padding.

**7** Carenado protector para evitar accidentes mientras las placas están en movimiento.

Protective fairing to avoid accidents while the plates are in movement.

**8** Selectores de ajuste de color amarillo para localizarlos fácilmente.

Yellow adjustment knobs for easy location.



**9** Regulación mediante sistema de palanca fácil.

Regulation by easy lever system.







**PC7007**  
EXTENSIÓN DE CUÁDRICEPS  
LEG EXTENSION

 DIMENSIONES | DIMENSIONS: 163 x 127 x 147 cm. | 
  PESO | WEIGHT: 247.2 kg. | 
  CARGA DE PLACAS / PLATE LOADING: 90.71 kg.





**PC7008**  
FEMORAL SENTADO  
LEG CURL

 DIMENSIONES | DIMENSIONS: 160 x 122 x 147 cm. | 
  PESO | WEIGHT: 247.2 kg. | 
  CARGA DE PLACAS / PLATE LOADING: 90.71 kg.





**PC7009**  
PRENSA SENTADO  
SEATED LEG PRESS

 DIMENSIONES | DIMENSIONS: 211 x 125 x 147 cm. | 
  PESO | WEIGHT: 367.2 kg. | 
  CARGA DE PLACAS / PLATE LOADING: 181.4 kg.





**PC7010**  
PATADA DE GLÚTEO  
GLUTE KICK BACK

 DIMENSIONES | DIMENSIONS: 131.5 x 117 x 153.6 cm. | 
  CARGA DE PLACAS / PLATE LOADING: 111.13 kg.





**PC7003**  
CURL DE BÍCEPS  
BICEPS CURL

 DIMENSIONES | DIMENSIONS: 185 x 140 x 147 cm. | 
  PESO | WEIGHT: 294.8 kg. | 
  CARGA DE PLACAS / PLATE LOADING: 133.81 kg.



**PC7004**  
FONDOS TRÍCEPS  
TRICEPS DIP

 DIMENSIONES | DIMENSIONS: 155 x 140 x 147 cm. | 
  PESO | WEIGHT: 244.7 kg. | 
  CARGA DE PLACAS / PLATE LOADING: 90.71 kg.





**PC7006**  
REMO SENTADO  
SEATED ROW

DIMENSIONES | DIMENSIONS: 180 x 135 x 147 cm. |
 PESO | WEIGHT: 291.3 kg. |
 CARGA DE PLACAS / PLATE LOADING: 133.81 kg.



**PC7005**  
JALÓN DORSAL  
LAT PULL DOWN

DIMENSIONES | DIMENSIONS: 180 x 135 x 147 cm. |
 PESO | WEIGHT: 288.3 kg. |
 CARGA DE PLACAS / PLATE LOADING: 133.81 kg.



**PC7001**  
PRESS DE PECHO  
SEATED CHEST PRESS

DIMENSIONES | DIMENSIONS: 183 x 160 x 147 cm. |
 PESO | WEIGHT: 268.6 kg. |
 CARGA DE PLACAS / PLATE LOADING: 111.13 kg.



**PC7002**  
PRESS DE HOMBROS  
SHOULDER PRESS

DIMENSIONES | DIMENSIONS: 180 x 155 x 147 cm. |
 PESO | WEIGHT: 268.6 kg. |
 CARGA DE PLACAS / PLATE LOADING: 111.13 kg.



# SERIES PC10

La línea PC10 comprende las necesidades de la sala de musculación. Por eso su diseño elegante y funcional se enfoca en maximizar tus sesiones de entrenamiento. La transmisión de fuerzas se realiza mediante cable y poleas construidas de la mejor calidad y durabilidad. La estructura de la línea es robusta y las zonas de apoyo confortables. La combinación de poleas altas, bajas y regulables asegura un entrenamiento total del cuerpo.

## CARACTERÍSTICAS TÉCNICAS

- Estructura construida en tubo oval de acero de 3 mm de grosor.
- Partes desmontables fabricadas en acero macizo con el que se evitan problemas de desgaste.
- Las barras guías son de acero rectificando y normalizado (cromo duro).
- Las placas son de acero calibrado, pintadas en negro. Éstas cuentan con anillos de teflón de una calidad superior, lo cual produce un deslizamiento óptimo evitando ruidos por fricción.
- El proceso de pintado de las máquinas se realiza en túnel de tratamiento de cuatro capas, que ofrece una absoluta garantía contra la corrosión: En la primera capa se procede al desengrasado y fosfatado en caliente. La segunda se trata de un prefosfatado a temperatura ambiente. En la tercera se procede a fosfatar en caliente. Y por último, se cubre la estructura con pintura epoxi en polvo.
- La transmisión de las fuerzas es mecánica por cable.
- Las máquinas están montadas sobre rodamientos (circulares o lineales) o ruedas de bronce y rodamientos.
- El tapizado cuenta con un relleno en goma espuma de 3 cm de espesor con 150 kg de presión, cubierto por una polipiel con tratamiento ignífugo.
- Incluye un carenado protector en la torre de placas para evitar posibles accidentes, y un selector de placas metálico con imán para mayor seguridad.

The PC10 line encompasses the needs of your workout zone. That's why its elegant and functional design focuses on maximizing your training sessions. The transmission of forces is carried out by means of cable and pulleys constructed of the best quality and durability. The structure of the line is robust and the support areas comfortable. The combination of high, low and adjustable pulleys ensures a total training of your body.

## TECHNICAL CHARACTERISTICS

- Structure built in 3 mm thick oval steel tube.
- Removable parts made of solid steel to avoid wear and tear problems
- The guide bars are made of rectified and normalized steel (hard chrome).
- The plates are made of calibrated steel, painted black. These have superior quality Teflon rings, which produces an optimal sliding avoiding friction noises.
- The painting process of the machines is carried out in a four-layer treatment tunnel, which offers an absolute guarantee against corrosion: The first layer is degreased and hot phosphated. The second is a pre-phosphate at room temperature. In the third phase, hot phosphating is carried out. And finally, the structure is covered with epoxy powder paint.
- The transmission of forces is mechanical by cable.
- The machines are mounted on bearings (circular or linear) or bronze wheels and bearings.
- The upholstery has a 3 cm thick foam rubber padding with 150 kg of pressure, covered by an imitation leather with fire retardant treatment.
- Includes a protective fairing on the plate tower to avoid possible accidents, and a metal plate selector with magnet for greater safety.

# PC10



## PC1001A

### 4 ESTACIONES 1 TORRE

4 STATIONS 1 TOWER

 DIMENSIONES | DIMENSIONS:  
345 x 195 x 230 cm.

 PESO | WEIGHT:  
710 kg.

 CARGA TOTAL / TOTAL PLATE LOAD:  
354 kg.

 CARGA DE PLACAS / PLATE LOADING:  
POLEA ALTA / HIGH PULLEY: 100 KG.  
POLEA BAJA / LOW PULLEY: 100 KG.  
TRICEPS / TRICEPS: 77 KG.  
POLEA REGULABLE / ADJUSTABLE PULLEY: 77 KG.



## PC1002

### 5 ESTACIONES 2 TORRES

5 STATIONS 2 TOWERS

 DIMENSIONES | DIMENSIONS:  
510 x 345 x 230 cm.

 PESO | WEIGHT:  
985 kg.

 CARGA TOTAL | TOTAL PLATE LOAD:  
431 kg.

 CARGA DE PLACAS | PLATE LOADING:  
POLEA ALTA | HIGH PULLEY: 100 KG.  
POLEA BAJA | LOW PULLEY: 100 KG.  
TRICEPS | TRICEPS: 77 KG.  
POLEA REGULABLE | ADJUSTABLE PULLEY: 77 KG. (x2)

COMPUESTO POR | COMPOSED BY :  
REF. PC1001A  
REF. PC1001B  
REF. PC1001C



## PC1003

### 8 ESTACIONES 2 TORRES

8 STATIONS 2 TOWERS

 DIMENSIONES | DIMENSIONS:  
590 x 410 x 230 cm.

 PESO | WEIGHT:  
1.420 kg.

 CARGA TOTAL | TOTAL PLATE LOAD:  
708 kg.

 CARGA DE PLACAS | PLATE LOADING:  
POLEA ALTA | HIGH PULLEY: 100 KG. (x2)  
POLEA BAJA | LOW PULLEY: 100 KG. (x2)  
TRICEPS | TRICEPS: 77 KG. (x2)  
POLEA REGULABLE | ADJUSTABLE PULLEY: 77 KG. (x2)

COMPUESTO POR | COMPOSED BY :  
REF. PC1001A (x2)  
REF. PC1001C



# SERIES PC40

## CARACTERÍSTICAS TÉCNICAS

- Estructura: Construida en tubo de acero inoxidable cuadrado 100 x 50 x 3.0 mm.
- Partes desmontables: Acero macizo con el que se evitan problemas de desgaste.
- Barras guías y placas: Las barras guías son de acero rectificado y normalizado (cromoduro). Las placas son de acero calibrado, pintadas en negro, estas tienen anillos de teflón de una calidad superior, lo cual produce un deslizamiento correcto y evitando ruidos por fricción.
- Pintura: Estructura con pintura epoxi negro mate en polvo.
- Transmisión: Por cable.
- Piezas móviles: Las máquinas están montadas sobre rodamiento (circulares o lineales) o ruedas de bronce y rodamientos.
- Tapizado: Realizado en goma espuma de 130 kg/m<sup>3</sup> de espesor y PU.
- Accesorios incluidos: Agarres de estribo nylon corto, agarres de estribo nylon largos, agarres estribo para tras nuca y agarres cuerda.



### PC4000A 4 ESTACIONES 1 TORRES 4 STATIONS 1 TOWERS

 DIMENSIONES | DIMENSIONS: 335 x 190 x 239 cm.  PESO | WEIGHT: 630 kg.  CARGA TOTAL | TOTAL PLATE LOAD: 380 kg.



 CARGA DE PLACAS | PLATE LOADING:  
POLEA ALTA | HIGH PULLEY: 100 KG.  
REMO BAJO | LOW ROW: 100 KG.  
POLEA TRÍCEPS | TRICEPS PULLEY: 80 KG.  
CRUCE DE POLEAS | CROSSOVER PULLEY: 100 KG.

## TECHNICAL CHARACTERISTICS

- Structure: Built in square stainless steel tube 100 x 50 x 3.0 mm.
- Removable parts: Solid steel to avoid wear problems.
- Guide bars and plates: The guide bars are made of rectified and normalized steel (chromoduride). The plates are made of calibrated steel, painted in black, they have Teflon rings of superior quality, which produces a correct sliding and avoids noise due to friction.
- Painting: The structure is coated with matt black epoxy powder paint
- Transmission: By cable.
- Moving parts: The machines are mounted on bearings (circular or linear) or bronze wheels and bearings.
- Upholstery: Made of 130 kg/m<sup>3</sup> thick foam rubber and PU.
- Accessories included: Short nylon stirrup grips, long nylon stirrup grips, stirrup grips for behind the neck press and rope grips.



### PC4002 5 ESTACIONES 2 TORRES 5 STATIONS 2 TOWERS

 DIMENSIONES | DIMENSIONS: 502 x 350 x 239 cm.  PESO | WEIGHT: 946 kg.  CARGA TOTAL | TOTAL PLATE LOAD: 480 kg.

 CARGA DE PLACAS | PLATE LOADING:  
POLEA ALTA | HIGH PULLEY: 100 KG.  
REMO BAJO | LOW ROW: 100 KG.  
POLEA TRÍCEPS | TRICEPS PULLEY: 80 KG.  
CRUCE DE POLEAS | CROSSOVER PULLEY: 100 KG. (x2)

COMPUESTO POR | COMPOSED BY :  
REF. PC4000A  
REF. PC4000B  
REF. PC4000C



### PC4003 8 ESTACIONES 2 TORRES 8 STATIONS 2 TOWERS

 DIMENSIONES | DIMENSIONS: 578 x 350 x 239 cm.

 PESO | WEIGHT: 1.426 kg.

 CARGA TOTAL | TOTAL PLATE LOAD: 760 kg.

 CARGA DE PLACAS | PLATE LOADING:  
POLEA ALTA | HIGH PULLEY: 100 KG. (x2)  
REMO BAJO | LOW ROW: 100 KG. (x2)  
POLEA TRÍCEPS | TRICEPS PULLEY: 80 KG. (x2)  
CRUCE DE POLEAS | PULLEY CROSSOVER: 100 KG. (x2)

COMPUESTO POR | COMPOSED BY :  
REF. PC4000A (X2)  
REF. PC4000C

# SERIES PC30

## CARACTERÍSTICAS TÉCNICAS

- Estructura: Construida en tubo de acero inoxidable cuadrado. 50 x 100 x 2.5 mm.
- Partes desmontables: Acero macizo con el que se evitan problemas de desgaste.
- Barras guías y placas: Las barras guías son de acero rectificado y normalizado (cromoduro). Las placas son de acero calibrado, pintadas en negro, estas tienen anillos de teflón de una calidad superior, lo cual produce un deslizamiento correcto y evitando ruidos por fricción.
- Pintura: Estructura con pintura epoxi negro mate en polvo.
- Transmisión: Por cable.
- Piezas móviles: Las máquinas están montadas sobre rodamiento (circulares o lineales) o ruedas de bronce y rodamientos.
- Tapizado: Realizado en goma espuma de 1.25g/cm3 de espesor y polipiel ignífuga.
- Accesorios incluidos: agarres estribo nylon, agarre recto para remo, agarre de jalón y agarre cuerda.



### PC3000A 4 ESTACIONES 1 TORRE 4 STATIONS 1 TOWER

DIMENSIONES | DIMENSIONS: 345 x 146 x 226 cm. PESO | WEIGHT: 642 kg. CARGA TOTAL | TOTAL PLATE LOAD: 360 kg.

CARGA DE PLACAS | PLATE LOADING:  
POLEA ALTA | HIGH PULLEY: 100 KG.  
REMO BAJO | LOW ROW: 100 KG.  
POLEA TRÍCEPS | TRICEPS PULLEY: 80 KG.  
CRUCE DE POLEAS | CROSSOVER PULLEY: 80 KG.

## TECHNICAL CHARACTERISTICS

- Structure: Built in square stainless steel tube. 50 x 100 x 2.5 mm.
- Removable parts: Solid steel to avoid wear problems.
- Guide bars and plates: The guide bars are made of rectified and normalized steel (chromoduride). The plates are made of calibrated steel, painted in black, they have Teflon rings of superior quality, which produces a correct sliding and avoids noise due to friction.
- Painting: The structure is coated with matt black epoxy powder paint.
- Transmission: By cable.
- Moving parts: The machines are mounted on bearings (circular or linear) or bronze wheels and bearings.
- Upholstery: Made of 1.25g/cm3 thick foam rubber and fireproof leatherette.
- Included accessories: nylon stirrup grips, straight rowing grip, pull-up grip and rope grip.



### PC3002 5 ESTACIONES 2 TORRES 5 STATIONS 2 TOWERS

DIMENSIONES | DIMENSIONS: 438 x 345 x 226 cm. PESO | WEIGHT: 820 kg. CARGA TOTAL | TOTAL PLATE LOAD: 440 kg.

CARGA DE PLACAS | PLATE LOADING:  
POLEA ALTA | HIGH PULLEY: 100 KG.  
REMO BAJO | LOW ROW: 100 KG.  
POLEA TRÍCEPS | TRICEPS PULLEY: 80 KG.  
CRUCE DE POLEAS | CROSSOVER PULLEY: 80 KG. (x2)

COMPUESTO POR | COMPOSED BY :  
REF. PC3000A  
REF. PC3000B  
REF. PC3000C



### PC3003 8 ESTACIONES 2 TORRES 8 STATIONS 2 TOWERS

DIMENSIONES | DIMENSIONS: 511 x 345 x 226 cm.

PESO | WEIGHT: 1.304 kg.

CARGA TOTAL | TOTAL PLATE LOAD: 720 kg.

CARGA DE PLACAS | PLATE LOADING:  
POLEA ALTA | HIGH PULLEY: 100 KG. (x2)  
REMO BAJO | LOW ROW: 100 KG. (x2)  
TRÍCEPS | TRICEPS: 80 KG. (x2)  
CRUCE DE POLEAS | PULLEY CROSSOVER: 80 KG. (x2)

COMPUESTO POR | COMPOSED BY :  
REF. PC3000A (X2)  
REF. PC3000C

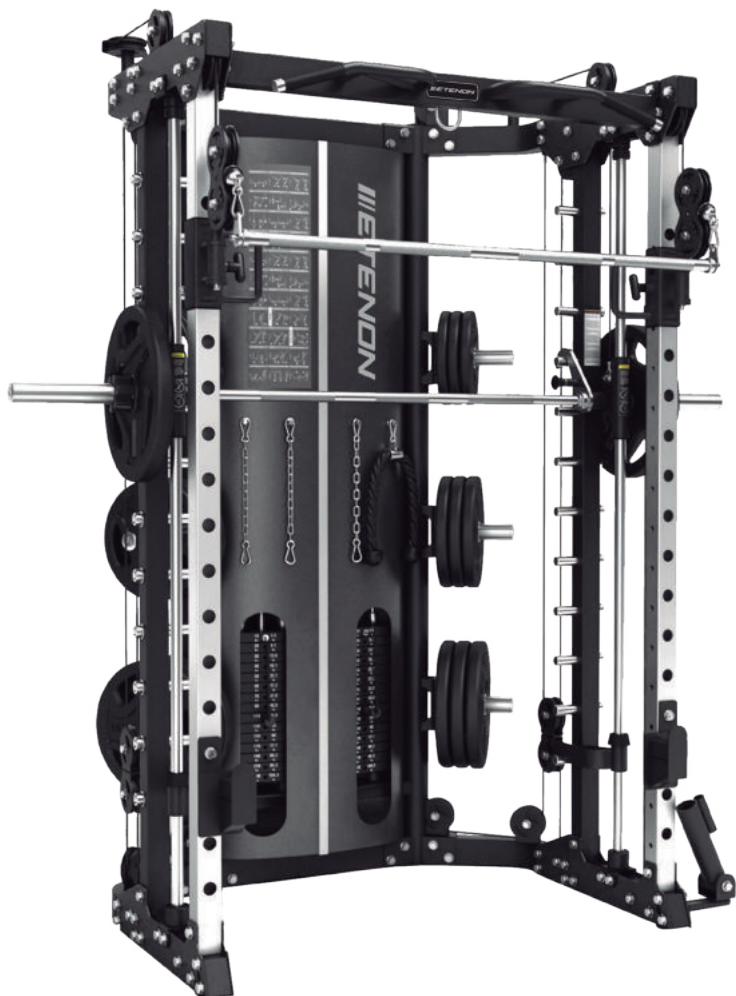

- BK30580PC (opcional) Se vende por separado.
- BK3058 (optional). Sold separately.

## PC0958

### MULTIFUNCIÓN BK58

#### MULTIFUNCTION BK58

Fabricado en tubo de acero de 50 x 50 x 3 mm. Incluye:

- Dos poleas laterales en cada columna.
- Multipower de discos y también de peso de placas.
- Dos tipos de agarres superiores con agarre variable.
- Anclaje de barra recta para trabajo de remo.
- Seis soportes de discos.
- Barra fija para dominadas.
- Panel con información y ejercicios.

Además incluye:

- Agarre de jalón.
- Barra recta.
- Soportes de seguridad.
- Soporte con rodillo.
- Soporte fondo paralelas.
- Agarre estribo nylon.
- Collarines.
- Soporte trunk blaster.
- Cadenas.
- Soporte en V.
- Ratio: 1:1.

Made of 50 x 50 x 3 mm steel tube. It includes:

- Two side pulleys on each column.
- Multipower of plates and also plate weights.
- Two types of top grips with variable grip.
- Straight bar anchorage for rowing work.
- Six plates supports.
- Fixed bar for pull-ups.
- Information and exercise panel.

Also includes:

- Pull-on grip.
- Straight bar.
- Safety supports.
- Roller support.
- Dip parallel support.
- Nylon stirrup grip.
- Collars.
- Trunk blaster support.
- Chains.
- V-shaped holder or grip.
- Ratio: 1:1.

**DIMENSIONES | DIMENSIONS:** 201 x 147.8 x 224 cm. **PESO | WEIGHT:** 400 kg. **CARGA DE PLACAS / PLATE LOADING:** 180 kg. (90 kg. x 2)

**PESO MÁXIMO DE USUARIO (BARRA DOMINADAS) / MAXIMUM USER WEIGHT (PULL UP BAR):** 300 kg.

**CARGA MÁXIMA MULTIPOWER / MAXIMUM MULTIPOWER WEIGHT:** 500 kg. (250 kg en cada torre / in each tower)

**CARGA MÁXIMA ACCESORIO PARA FONDOS / MAXIMUM LOAD ACCESSORY FOR TRICEPS DIPS:** 300 kg.

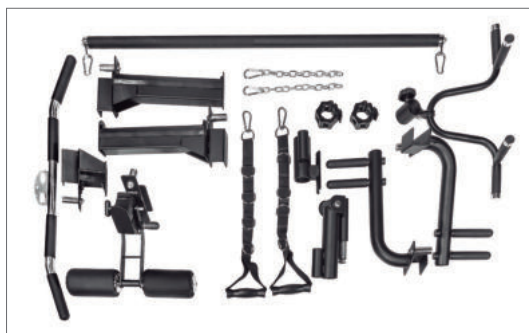

- Accesorios incluidos
- Included accessories

## PC0950

### DUAL DOBLE POLEA-MULTIPOWER

#### DUAL CABLE-MULTIPOWER

- Estructura en tubo oval de acero de 100 x 3 mm de grosor.
- Transmisión por cable de 4.8 mm y agarres en goma.
- Barra de dominadas y presas de rocódromo.
- Carenado protector en la torre de placas para evitar posibles accidentes y selector de placas metálico con imán para mayor seguridad.
- Barras de almacenamiento recubiertas de goma en ángulos para evitar que los discos se caigan.
- Ganchos para los elásticos de resistencia.
- Structure built in a 100 X 3 mm. oval steel tube.
- 4.8mm cable transmission and rubber grips.
- Pull-up bar and rhodochrome weights.
- Protective fairing on the plate tower to avoid possible accidents and metal plate selector with magnet for greater safety.
- Angled rubberized storage bars to prevent Plates from falling out.
- Hooks for resistance bands.

**DIMENSIONES | DIMENSIONS:** 234.3 x 132 x 210 cm.

**PESO | WEIGHT:** 486 kg.

**CARGA DE PLACAS / PLATE LOADING:** 154 kg. (77 kg. x 2)

**PESO MÁXIMO DE USUARIO / MAXIMUM USER WEIGHT:** 150 kg.





## PC0970

### DUAL FUNCIONAL TRAINER

#### DUAL FUNCTIONAL TRAINER

- Estructura construida en tubo de acero inoxidable cuadrado Q235.
- Partes desmontables de acero macizo con el que se evitan problemas de desgaste.
- Barras guías y placas: Las barras guías son de acero rectificado y normalizado (cromoduro). Las placas son de acero calibrado, pintadas en negro, estas tienen anillos de teflón de una calidad superior, lo cual produce un deslizamiento correcto y evitando ruidos por fricción.
- Cuenta con transmisión por cable trenzado de alta resistencia.
- Regulación de poleas bajas.
- Incluye agarres dominadas.
- Incorpora selectores de aluminio magnéticos con alta durabilidad y muy estéticos.
- Peso de las placas: 220LB x 2 = 440 lbs / 100 kg x 2 = 200 kg.
- Partes acolchadas con Pu Foam.

#### Accesorios que incluye:

- Banco.
- Paralela para fondos.
- Soporte de seguridad para barra olímpica.
- Carenado para placas.
- Set de Agarres.

#### Posibilidad adquirir accesorios opcionales para complementar este modelo:

- Soporte para kettlebells.
- Soporte para balones.
- Soporte para saco de boxeo.
- Gancho de cuerda.



- Structure built in Q235 square stainless steel tube.
- Removable parts made of solid steel to avoid wear problems.
- Guide bars and plates: The guide bars are made of ground and normalized steel (chromide). The plates are made of calibrated steel, painted black, they have superior quality Teflon rings, which produces correct sliding and avoids noise due to friction.
- It has high resistance braided cable transmission.
- Low pulley adjustment.
- It includes pull-up holds.
- It incorporates magnetic aluminum selectors with high durability and very aesthetic.
- Plates weight: 220LB x 2 = 440 lbs / 100 kg x 2 = 200 kg.
- Parts padded with polyurethane foam.

#### Accesorios included:

- Bench.
- Parallel bar.
- Lifting safety.
- Weight plate cover.
- Set of grips.

#### Possibility of purchasing optional accessories to complement this model:

- Kettlebell holder.
- Ball holder.
- Frame boxing.
- Rope hook.

 DIMENSIONES | DIMENSIONS: 184.5 x 101.5 x 235 cm. |  PESO | WEIGHT: 425 kg. |  CARGA DE PLACAS / PLATE LOADING: 200 kg. (100 kg. x 2)

## PC0960

### MULTIFUNCIÓN BRUTE FIT PRO

#### MULTIFUNCTION BRUTE FIT PRO

- Fabricada en tubo oval de acero Q235 de alta calidad de 80 x 50 de 3mm de espesor.
- Estructura soldada para garantizar un uso duradero.
- Cuenta con una capa de pintura negra mate en polvo para una fijación total y una alta resistencia.
- Partes desmontables de acero macizo con el que se evitan problemas de desgaste.
- Las barras guías son de acero rectificado y normalizado (cromoduro) ajustables verticalmente.
- Biomecánica de máquina diseñada especialmente para permitir la accesibilidad a cualquier tipo de usuario.
- Cuenta con dos poleas en aluminio móviles,
- Las placas son de acero calibrado, pintadas en negro, estas tienen anillos de teflón de una calidad superior, lo cual produce un deslizamiento correcto evitando ruidos por fricción.
- Rodamientos industriales y tornillería de alta calidad.
- Configuración de la estructura en ángulo recto para garantizar una perfecta adaptación estructural.
- Transmisión por cable.
- Soportes para almacenaje de accesorios
- Barra dominadas con agarres abiertos/cerrados
- Tacos de PVC blandos antideslizantes en su base

La máquina presenta un listado variado de accesorios para diferentes tipos de ejercicios:



- Brazo de suspensión
- Barra recta
- Biela del brazo de suspensión
- Plataforma invertida
- Plataforma (Dimensiones: 72 x 40 cm)
- Agarres estribo para poleas
- Rodillos acolchados para piernas
- Barra recta pequeña
- Soportes apoyo barra olímpica
- Soportes para fondos
- Agarre cuerdas nylon
- Cierres para barra olímpica
- Soporte para barra sentadillas

- Soft non-slip PVC studs on the base.

The machine presents a varied list of accessories for different types of exercises:

- Suspension Arm
- Straight bar
- Suspension arm connecting rod
- Inverted platform
- Platform (Dimensions: 72 x 40 cm)
- Stirrup grips for pulleys
- Padded leg rollers
- Small straight bar
- Olympic bar support supports
- Background supports
- Nylon rope grip
- Olympic bar closures
- Squat bar support

- Made of high quality 80 x 50 Q235 steel oval tube, 3mm thick.
- Welded structure to ensure long-lasting use.
- It has a layer of matte black powder paint for total fixation and high resistance.
- Removable parts made of solid steel to avoid wear problems.
- The guide bars are made of rectified and normalized steel (chromide) and are vertically adjustable.
- Machine biomechanics specially designed to allow accessibility to any type of user.
- It has two mobile aluminum pulleys,
- The plates are made of calibrated steel, painted black, they have superior quality Teflon rings, which produces correct sliding, avoiding friction noises.
- Industrial bearings and high quality screws.
- Configuration of the structure at right angles to guarantee perfect structural adaptation.
- Cable transmission.
- Hanging brackets for accessory storage
- Pull-up bar with open/close grips

 DIMENSIONES | DIMENSIONS: 180 x 223 x 229 cm. |  PESO | WEIGHT: 448 kg. |  CARGA DE PLACAS / PLATE LOADING: 200 kg. (100 kg. x 2)





## PC1801

### DUAL CABLE TRAINER

#### DUAL CABLE TRAINER

- Poleas de aluminio con rodamientos que aseguran un movimiento fluido y proporcionan una gama casi ilimitada de ejercicios.
  - Cada brazo gira vertical y horizontalmente mediante 12 ajustes que permiten ejecutar cualquier tipo de movimiento.
  - Los brazos son contra-equilibrados para facilitar la colocación.
  - El cable de cada uno de los brazos mide 234 cm. lo que te permite realizar una completa gama de ejercicios tanto bilateral como unilateralmente.
  - Las placas de peso se encuentran cubiertas para garantizar la seguridad del usuario. Las placas de peso duales permiten entrenar simultáneamente a dos usuarios.
  - Construida con acero de calibre 11 y 7 y terminado con un proceso electrostático con recubrimiento de polvo.
  - Una proporción 3:1 ha sido incorporada a esta 2ª generación de Dual Cable con la misma resistencia de movimiento, pero con menos peso.
  - Los grips pueden moverse de forma independiente ofreciendo multitud de ejercicios.
- Aluminum pulleys with bearings that ensure smooth movement and provide an almost unlimited range of exercises.
  - Each arm rotates vertically and horizontally through 12 adjustments that allow any type of movement to be executed.
  - The arms are counter-balanced to facilitate positioning.
  - The cable of each of the arms measures 234 cm. Which allows to perform a full range of exercises both bilaterally and unilaterally.
  - Weight plates are covered to ensure user safety. Dual weight plates allow two users to train simultaneously.
  - It's constructed of 11- and 7-gauge steel and finished with an electrostatic powder-coated process.
  - A 3:1 ratio has been incorporated into this 2nd generation of Dual Cable with the same resistance to movement, but with less weight.
  - The grips can be moved independently offering a multitude of exercises.

 **DIMENSIONES | DIMENSIONS:**  
130 x 185 x 318 cm.

 **PESO | WEIGHT:**  
350 kg.

 **CARGA DE PLACAS / PLATE LOADING:**  
163 kg. - 81.5 kg en cada torre / in each tower.







## PC0926

### POLEA AJUSTABLE INDIVIDUAL SINGLE CABLE TOWER

- Estructura: Construida en tubo de acero inoxidable cuadrado. 100 x 50 x 3 mm.
- 4 anclajes, dos en la parte baja y dos en la superior.
- Peso placas: 100 kg (19 placas de 5 kg + placa estática superior).
- Las barras guías son de acero rectificando y normalizado (cromoduro).
- Las placas son de acero calibrado, pintadas en negro, estas tienen anillos de teflón de una calidad superior, lo cual produce un deslizamiento correcto y evitando ruidos por fricción.
- Agarres cómodos fabricados en goma. Ofrecen una muy buena sensación de agarre al contacto.
- Transmisión por cable reforzado.
- Carenado delantero en policarbonato para evitar accidentes mientras las placas están en movimiento.
- Selectores de ajuste de color para localizarlos fácilmente.
- Made of square stainless steel tube. 100 x 50 x 3 mm.
- 4 anchorages, two at the bottom and two at the top.
- Plate weight: 100 kg (19 plates of 5 kg + upper static plate).
- The guide bars are made of rectified and standardised steel (chromium iodide).
- The plates are made of calibrated steel, painted black, they have Teflon rings of a superior quality, which produce a correct sliding and avoid friction noises.
- Comfortable rubber grips. They offer a very good feeling of grip on contact.
- Reinforced cable transmission.
- Polycarbonate front fairings to prevent accidents while the plates are in motion.
- Colour setting selectors for easy location.

 **DIMENSIONES | DIMENSIONS:** 47 x 46 x 220 cm. |  **PESO | WEIGHT:** 136 kg. |  **CARGA DE PLACAS / PLATE LOADING:** 100 kg.



- PC0926A. Se vende por separado.
- PC0926A. Sold separately.



- PC0926B. Se vende por separado.
- PC0926B. Sold separately.



## VA1000-B

### POLEA AJUSTABLE INDIVIDUAL VEKTOR SINGLE CABLE TOWER VEKTOR

- Estructura: Tubo en acero inoxidable 38 x 38 x 1.5 mm.
- Distancia entre agujeros (regulación): 80 mm.
- Consola: LED.
- Información y programas: Peso, tiempo, ciclo, intervalo, calorías, pulso, CM/Min.
- Programa cuenta atrás y programa de intervalos.
- Resistencia: Por aire al vacío.
- 6 niveles ajustables de resistencia. (5, 10, 15, 20, 25 y 30 kg).
- Polea ajustable: 21 posiciones.
- Accesorios incluidos: 2 pares de guantes para enganchar mosquetón + 1 agarre tobillero + 1 par agarre estribo nylon, y una herramienta para mantenimiento.
- Medida de la plataforma: 120 x 59 x 2.5 cm.
- Structure: Stainless steel tube 38 x 38 x 1.5 mm.
- Distance between holes (regulation): 80 mm.
- Console: LED.
- Information and programs: Weight, time, cycle, interval, calories, pulse, CM/Min.
- Countdown program and interval program.
- Resistance: By air to vacuum.
- 6 adjustable resistance levels. (5, 10, 15, 20, 25 and 30 kg).
- Adjustable pulley: 21 positions.
- Accessories included: 2 pairs of gloves to attach carabiner + 1 ankle grip + 1 pair of nylon stirrup grip, and a maintenance tool.
- Platform measurement: 120 x 59 x 2.5 cm.

 **DIMENSIONES | DIMENSIONS:** 31 x 39 x 193 cm. |  **PESO | WEIGHT:** 41.2 kg.



## PC0921

### DUAL FUNCIONAL TRAINER PRO

#### DUAL FUNCTIONAL TRAINER PRO

- Estructura construida en tubo oval de acero de 3 mm.
- Las barras guías son de acero rectificando y normalizado (cromoduro).
- Las placas son de acero calibrado, pintadas en negro.
- Transmisión por cable.
- Agarres en goma.
- Tapizado realizado en goma espuma de 3 cm. de espesor con 150 kg. de presión, y polipiel ignífuga.
- Structure built in oval steel tube of 3 mm.
- The guide bars are made of rectified and standardized steel (hardchrome).
- The plates are of calibrated steel, painted in black.
- Cable transmission.
- Rubber grips.
- Upholstery made of 3cm thickness foam rubber with 150 kg. of pressure, and fire retardant leatherette.

**DIMENSIONES | DIMENSIONS:**  
84 x 152 x 212 cm.

**PESO | WEIGHT:**  
325 kg.

**PESO BRAZO REGULABLE | ADJUSTABLE ARM WEIGHT:**  
29 kg. Pieza opcional / Optional piece.

**CARGA DE PLACAS / PLATE LOADING:**  
154,22 kg. (77,11 kg. x 2)



- Esta máquina tiene la posibilidad de incluir soporte regulable con referencia PC0921-OPT (opcional) Se vende por separado.
- This machine has the possibility to include an adjustable support with reference PC0921-OPT (optional). Sold separately.

## PC0925

### DUAL FUNCIONAL TRAINER BK

#### DUAL FUNCTIONAL TRAINER BK

- Fabricada en tubo de acero 50 x 70 x 2 mm.
- Pintura polvo de poliéster anticorrosiva de color negro mate con gran calidad de acabado.
- Las poleas de transmisión en aluminio incorporan rodamientos de bolas que garantizan un movimiento suave y silencioso.
- Las barras guías son de acero inoxidable (cromoduro) ajustables verticalmente.
- Ratio: 1:2.
- 21 agujeros de regulación.
- Distancia entre agujeros: 80mm.
- Guías de acero inoxidable.
- Patas con protectores en PVC.
- Carenados delantero y trasero para evitar accidentes mientras las placas están en movimiento.
- Accesorios incluidos:  
1 par agarres estribo nylon.  
1 agarre tobillero.  
1 agarre barra recta.  
1 agarre estribo curvo.  
1 cinturón.
- Made of steel tube 50 x 70 x 2 mm.
- Anti-corrosive polyester powder paint in matt black with a high quality finish.
- The aluminium drive pulleys are fitted with ball bearings to ensure smooth and quiet movement.
- Vertically adjustable stainless steel (chrome-plated) guide rods.
- Ratio: 1:2.
- 21 adjustment holes.
- Hole spacing: 80mm.
- Stainless steel guides.
- Multi-grip pull-up bar.
- Legs with rubber protectors.
- Accessories included:  
1 pair of nylon stirrup grips.  
1 ankle grip.  
1 straight bar grip.  
1 curved stirrup grip.  
1 belt.

**DIMENSIONES | DIMENSIONS:** 116 x 153,5 x 223 cm. | **PESO | WEIGHT:** 289,4 kg. | **CARGA DE PLACAS / PLATE LOADING:** 200 kg. (100 kg x 2)







## PC0923

### DUAL FUNCIONAL TRAINER ELITE

#### DUAL FUNCTIONAL TRAINER ELITE

- Estructura construida en tubo oval de acero de 50 x 100 x 2 mm.
- Partes desmontables de acero macizo con el que se evitan problemas de desgaste.
- Las barras guías son de acero rectificad y normalizado (cromoduro) ajustables verticalmente.
- Poleas en aluminio.
- Las placas son de acero calibrado, pintadas en negro, estas tienen anillos de teflón de una calidad superior, lo cual produce un deslizamiento correcto evitando ruidos por fricción.
- Ratio: 1:2.
- El proceso de pintado de las máquinas se realiza en túnel de tratamiento de cuatro capas, que ofrece una absoluta garantía contra la corrosión. En la primera capa se procede al desengrasado y fosfatado en caliente.
- La segunda se trata de un prefosfatado a temperatura ambiente. En la tercera se procede a fosfatar en caliente. Y por último, se cubre la estructura con pintura epoxi en polvo.
- Transmisión por cable.
- Protector de columna de placas.
- La máquina están montadas sobre rodamientos (circulares o lineales) o ruedas de bronce y rodamientos.
- Agarres en goma.
- Soportes para almacenaje de accesorios. Incluye 1 par de agarres estribo nylon.
- Barra dominadas con agarres abiertos/cerrados - Diámetro 25 x 2 mm - Soporta hasta 200 kg.
- Distancia entre agujeros de regulación: 80 mm.
- Structure made of 3 mm oval steel tube.
- Removable parts made of solid steel with which wear problems are avoided.
- The guide bars are made of ground and normalized steel (hard chrome) vertically adjustable.
- Aluminium pulleys.
- The plates are made of calibrated steel, painted black, they have superior quality Teflon rings, which produces a correct slide avoiding friction noises.
- Ratio: 1:2.
- The painting process of the machines is carried out in a four-layer treatment tunnel, which offers an absolute warranty against corrosion. In the first layer, degreasing and hot phosphating are carried out. The second is about of a prephosphate at room temperature. In the third, hot phosphating is carried out. And finally, it covers the structure with epoxy powder paint.
- Cable transmission.
- Plate column protector.
- The machine is mounted on bearings (circular or linear) or bronze wheels and bearings.
- Rubber grips.
- Accessory storage brackets. Includes 1 pair of nylon stirrup grips.
- Pull-up bar with open/closed grips - Diameter 25 x 2 mm - Supports up to 200 kg.
- Distance between adjustment holes: 80 mm.

 DIMENSIONES | DIMENSIONS: 123.3 x 164 x 223.3 cm. |
  PESO | WEIGHT: 380 kg. |
  CARGA DE PLACAS / PLATE LOADING: 200 kg. (100 kg. x 2)



## PC6020

### DUAL FUNCIONAL TRAINER PRO+

#### DUAL FUNCTIONAL TRAINER PRO+

- Diseñadas a través de un exhaustivo estudio en biomecánica para un trabajo óptimo.
- Fabricada en tubo de acero: 120 x 50 x 3.0 mm.
- Pintura polvo de poliéster anticorrosiva de color negro mate con gran calidad de acabado.
- Dispone de cables de transmisión de acero reforzados de 3 mm de grosor, sumamente flexibles y resistentes con funda protectora de 2 mm. La sensación y movimiento es siempre fluida.
- Las poleas de transmisión incorporan rodamientos de bolas que garantizan un movimiento suave y silencioso.
- La estructura de la línea PC60 cuenta con soldaduras reforzadas.
- Tracción fluida. Dispone de poleas de PA con material autolubrificante. Baja fricción y alta durabilidad.
- Incluye pictogramas explicativos para la correcta ejecución del ejercicio. (Posibilidad de incluir código QR con acceso a vídeo).
- Incorpora selectores de aluminio magnéticos con alta durabilidad y muy estéticos.
- Agarres cómodos fabricados en goma no porosa. Ofrecen una muy buena sensación de agarre y seguridad al contacto.
- Las barras guías son de acero inoxidable.
- Regulación en altura de ambas poleas.
- Patas con protectores en goma.
- Carenados delantero y trasero metálico para evitar accidentes mientras las placas están en movimiento.
- Torre de placas con indicadores de peso en kg.

- Designed through an exhaustive study in biomechanics for optimal work.
- Made of steel tube: 120 x 50 x 3.0 mm.
- Anti-corrosive polyester powder paint in matt black with a high quality finish.
- It has 3 mm thick reinforced steel transmission cables, extremely flexible and resistant with a 2 mm protective sheath. The feel and movement is always smooth.
- The drive pulleys are fitted with ball bearings to ensure smooth and quiet movement.
- The structure of the PC60 line has reinforced welds.
- Smooth traction. PA pulleys with self-lubricating material. Low friction and high durability.
- Includes explanatory pictograms for the correct execution of the exercise (possibility of including QR code with access to video).
- Includes highly durable and aesthetic magnetic aluminium selectors.
- Comfortable grips made of non-porous rubber. They offer a very good feeling of grip and safety on contact.
- The guide rods are made of stainless steel.
- Height adjustment of both pulleys.
- Legs with rubber protectors.
- Metal front and rear fairings to prevent accidents while the plates are in motion.
- It incorporates magnetic aluminum selectors with high durability and very aesthetic.
- Regulation of both hanging pulleys.
- Legs with PVC protectors.
- Front and rear fairings to avoid accidents while the plates are in motion.
- Plate tower with weight indicators in kg.

 DIMENSIONES | DIMENSIONS: 94 x 166 x 224 cm. |
  PESO | WEIGHT: 405 kg. |
  CARGA DE PLACAS / PLATE LOADING: 200 kg. (100 kg. x 2)

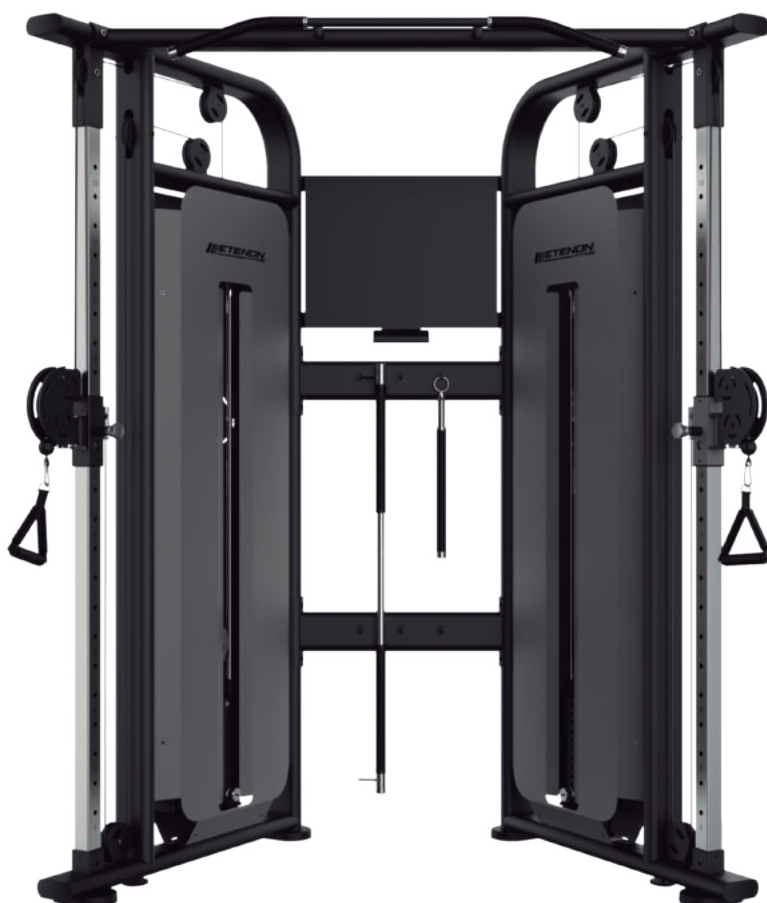



## PC0924

### MULTIPOWER INCLINADO ELITE

INCLINED MULTIPOWER ELITE

- Estructura construida en tubo oval de acero de alta calidad de 50 x 120 mm y 2 mm de espesor.
- Topes de seguridad ajustables en altura.
- 8° de inclinación.
- Sistema de anclaje de 13 posiciones con 9 cm de espaciado.
- Patas con protectores en PVC.
- Structure built in high quality oval steel tube measuring 50 x 120 mm and 2 mm thick.
- Height adjustable safety stops.
- 8° inclination.
- 13-position anchoring system with 9 cm spacing.
- Legs with PVC protectors

DIMENSIONES | DIMENSIONS: 221.6 x 135.8 x 224.2 cm. | PESO | WEIGHT: 137 kg. | PESO DE LA BARRA | BARBELL WEIGHT: 15 kg.



## PC0927

### MULTIPOWER/RACK SENTADILLA ELITE

MULTIPOWER/SQUAT RACK ELITE

- Estructura construida en tubo oval de acero de alta calidad de 50 x 100 mm y 2 mm de espesor.
- Topes de seguridad ajustables en altura.
- 6° de inclinación.
- Sistema de anclaje de 10 posiciones.
- Patas con protectores en PVC.
- 8 pinchos de discos.
- Structure built in high quality oval steel tube measuring 50 x 100 mm and 2 mm thick.
- Height adjustable safety stops.
- 6° inclination.
- 10-position anchoring system.
- Legs with PVC protectors.
- 8 disc hangers.

DIMENSIONES | DIMENSIONS: 210.2 x 123 x 223.4 cm. | PESO | WEIGHT: 137 kg. | PESO DE LA BARRA | BARBELL WEIGHT: 21 kg.



## PC0920

### MULTIPOWER PRO

MULTIPOWER PRO

- Estructura construida en tubo oval de acero de alta calidad de 3 mm. de espesor.
- Barra para discos de 50 mm.
- Topes de seguridad ajustables en altura.
- Sistema de anclaje de 11 posiciones.
- Protectores en PVC en las zonas de contacto con el suelo
- 8 colgadores de discos.
- Structure made of high quality 3 mm thick oval steel tube.
- Bar for 50 mm Plates.
- Height-adjustable safety stops
- 11-position anchoring system.
- PVC protective pads on the ground contact areas.
- 8 disc hangers.

DIMENSIONES | DIMENSIONS: 213 x 95 x 212 cm. | PESO | WEIGHT: 146 kg. | PESO DE LA BARRA | BARBELL WEIGHT: 14.4 kg.



## PTT0222

### MULTIPOWER CON CONTRAPESO PRO

MULTIPOWER WITH COUNTERWEIGHT PRO

- Estructura construida en tubo oval de acero de 3 mm.
- Tacos de PVC blando en las patas que garantizan la estabilidad y evitan el desgaste.
- Cuenta con un sistema de contrapeso que facilita la compensación del peso de la barra.
- 3 mm. steel oval tube structure.
- Soft PVC studs on the legs guarantee stability and prevent wear and tear.
- It has a counterweight system that makes it easy to compensate for the weight of the bar from the machine

DIMENSIONES | DIMENSIONS: 217 x 158 x 239 cm. | PESO | WEIGHT: 198 kg.



## PTT0280

### HALF RACK PRO+

HALF RACK PRO+

- 6 portadiscos de almacenamiento en los laterales de la parte trasera, 1 porta-barras con posibilidad de montaje en los laterales en ambas columnas delanteras y soportes de seguridad y de sentadillas ajustables en altura.
- Tornillería con estándar de calidad europeo.
- Agarres superiores en pronación y supinación.
- Soporte para barra.
- Un par de soportes de seguridad.
- Pintura en polvo con base poliéster lacado al horno, apta para exteriores y resistente a radicación UV
- Estructura de la base en acero de alta resistencia 150 x 50 x 3 mm.
- Empuñaduras de goma porosa para mayor confortabilidad y agarre.
- Posibilidad de trabajar los ejercicios con elásticos, gracias a sus extensiones laterales de la base.
- El Rack es compatible con las plataformas PTT0298 y PTT0299, preparadas para atornillar directamente a la base del Rack.
- Las plataformas compatibles tanto de 3 x 1 metro como de 3 x 2 metros, fabricadas en acero de alta resistencia de 60 x 40, llevan en la parte central madera y en la parte delantera una rampa para facilitar la entrada a la plataforma.
- Fabricado en España.



## PTT0299

CON PLATAFORMA DE 1 X 3 M. | WITH 1 X 3 M PLATFORM.

## PTT0298

CON PLATAFORMA DE 2 X 3 M. | WITH 2 X 3 M PLATFORM.



- 6 weight plate holders on the sides at the rear, 1 bar holder with side mounting possibility on both front columns and height-adjustable safety and squat racks.
- Screws with European quality standard.
- Bar support.
- Safety brackets.(Pair)
- Upper pronation and supination grips.
- Powder coating with baked-on polyester base, suitable for outdoor use and resistant to UV radiation.
- Main structure in high resistance steel 150 x 50 x 3 mm.
- Porous rubber handles for greater comfort and grip.
- Possibility to work on the exercises with elastic bands, thanks to the lateral extensions of the base.
- The Rack is compatible with the PTT0298 and PTT0299 platforms, prepared to be screwed directly to the base of the Rack.
- Compatible platforms both 3x1 meter and 3x2 meters, made of high resistance steel of 60x40, with wood in the central part and a ramp in the front part to facilitate the entrance to the platform.
- Made in Spain.

DIMENSIONES | DIMENSIONS:  
167 x 175 x 245 cm.

PESO | WEIGHT:  
210 kg.



## PTL204

### JAULA POTENCIA-SENTADILLA CON PLATAFORMA PRO+

POWER CAGE PLATFORM SQUAT PRO+

- Fabricado en acero con tubo de 70 x 140 x 3 mm. de grosor. Incluye plataforma de levantamiento fabricada en madera, caucho y acero de 60 x 60 x 3 mm. de grosor, que proporciona al usuario una base estable que además protege el suelo.
- Terminación en pintura epoxi negra y roja.
- Made from steel with 70 x 140 x 3 mm. tube. thick Includes lifting platform made of wood rubber and 60 x 60 x 3 mm. thickness steel, which provides a stable base to the user and also protects the floor.
- Black and red epoxy paint finish.

DIMENSIONES | DIMENSIONS:  
320 x 380 x 250 cm.

PESO | WEIGHT:  
710 kg.



## 105311

### JAULA DE SENTADILLA ELITE

SQUAT RACK ELITE

- Fabricada en acero con tubo de 6 x 6 cm. y 2 mm. de grosor.
- Terminación en pintura epoxi negra.
- Soporte para barra de sentadillas adaptable a diferentes alturas.
- Sistema de seguridad regulable en altura.
- 6 soportes en acero inoxidable para almacenaje de discos.
- Made of steel with 6 x 6 cm tube. and 2 mm. thick.
- Finishing in black epoxy paint.
- Squat bar support adaptable to different heights.
- Height adjustable safety system.
- 6 stainless steel supports for plates storage.

Discos y barra no incluidos.  
Plates and bar not included.

DIMENSIONES | DIMENSIONS:  
183 x 184 x 228 cm.

PESO | WEIGHT:  
132 kg.



## 10203 RACK DE SENTADILLAS ELITE

SQUAT RACK ELITE

- Fabricado en acero de 75 x 75 y 3 mm. de grosor. • Made of steel, 75 x 75 and 3 mm thick.
- DIMENSIONES | DIMENSIONS:** 168.5 x 157.5 x 196 cm. | 
 **PESO | WEIGHT:** 125 kg. | 
 **CARGA MÁXIMA | MAXIMUM LOAD:** 300 kg.

Discos y barra no incluidos.  
Plates and bar not included.



## 10205 RACK SENTADILLAS ABATIBLE ELITE

FOLDABLE SQUAT RACK ELITE

- Rack anclado a la pared, con estructura fabricada en acero y terminación en epoxi color negro.
- Su composición abatible hace que se recoja con facilidad y no ocupe espacio.
- Rack anchored to the wall, with a steel structure and a black epoxy finish.
- Its folding composition makes it easy to collect and does not take up space.

**DIMENSIONES | DIMENSIONS:** 60 x 150 x 231 cm. | 
 **PESO | WEIGHT:** 67 kg.

Discos y barra no incluidos.  
Plates and bar not included.

## SS700 RACK X2

X2 RACK

- Rack hecho de acero.
- Método de corte láser de fibra óptica.
- Carga máxima recomendada del conjunto 550 kg.
- Perfil del pilar 60 x 60 x 2 mm.
- Alturas para soportes: 16.
- Diámetro de orificio para soportes: 1 pulgada.
- Distancia entre orificios: 10 cm.
- Distancia entre altura n°1 y suelo: 26 cm.
- Distancia entre altura n°16 y suelo: 174 cm.
- Rack made of steel.
- Fibre optic laser cutting method.
- Maximum recommended load of the assembly 550 kg.
- Pillar profile 60x60x2 mm.
- Heights for supports: 16.
- Hole diameter for supports: 1 inch.
- Distance between holes: 10 cm.
- Distance between height n°1 and floor: 26 cm.
- Distance between height n°16 and floor: 174 cm.

**DIMENSIONES | DIMENSIONS:** 49 x 51 x 196 cm. | 
 **PESO | WEIGHT:** 35 kg.

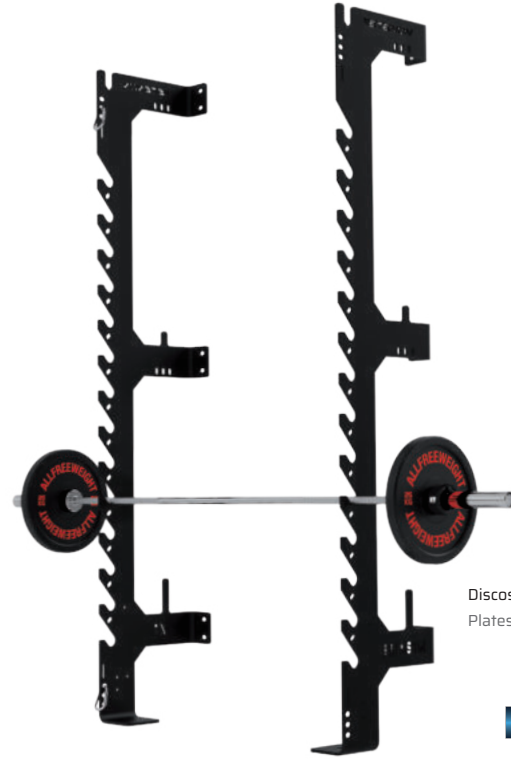

FABRICADO EN ESPAÑA

Discos y barra no incluidos.  
Plates and bar not included.

**BRONSON**  
-ETEND-

## CC700 RACK X1

X1 RACK

- Rack compatible con productos para fondos de paralelas, accesorios para sentadillas, o accesorios para bandas de resistencia.
- Orificios de anclaje alargados para fácil instalación y ajuste de separación. 19 por cada columna.
- 2 Ranuras para entrenamiento en suspensión por cada columna.
- 4 Apéndices y 6 puntos de anclaje para accesorios (gomas, cinturones, collarines, etc.) por cada columna.
- Pintura en polvo al horno para exteriores con acabado texturizado de color negro.
- Carga máxima recomendada del conjunto: 550 kg.
- Rack compatible with products like dips, squat accessories, of resistance band accessories.
- Elongated anchor holes for easy installation and spacing adjustment. 19 per column.
- 2 Suspension training slots per column.
- 4 Appendages and 6 anchorage points for accessories (rubber bands, belts, collars, etc.) per column.
- Oven-baked powder coating for outdoor use with black textured finish.
- Maximum recommended set load: 550 kg.

**DIMENSIONES | DIMENSIONS:** 42 x 15 x 221 cm. | 
 **PESO | WEIGHT:** 70 kg.



FABRICADO EN ESPAÑA

Discos y barra no incluidos.  
Plates and bar not included.

**BRONSON**  
-ETEND-



## PTT0207F

### RACK DE SENTADILLAS PTT02

SQUAT RACK PTT02

- Estructura construida en tubo oval de acero de 3 mm.
- Tacos de PVC blando en las patas que garantizan la estabilidad y evitan el desgaste.
- Los soportes de las barras están hechos de poliuretano termoplástico, un material altamente resistente y que amortigua el impacto de las barras.
- Structure made of 3 mm oval steel tube.
- Soft PVC blocks on the legs guarantee stability and prevent wear and tear.
- The bar supports are made of thermoplastic polyurethane, a highly resistant material that cushions the impact of the bars.

**DIMENSIONES | DIMENSIONS:** 186 x 165 x 201 cm. | **PESO | WEIGHT:** 145 kg.



Discos y barra no incluidos.  
Plates and bar not included.

## 10204

### JAULA DE SENTADILLAS

SQUAT RACK

- Estructura de Q235 acero al carbono de 50 x 50 x 2 mm. de grosor.
- Incluye barra de dominadas con múltiples agarres.
- Structure of Q235 carbon steel of 50 x 50 x 2 mm. thickness.
- Includes pull-up bar with multiple grips.

**DIMENSIONES | DIMENSIONS:** 121.5 x 149 x 214.5 cm. | **PESO | WEIGHT:** 63 kg. | **CARGA MÁXIMA | MAXIMUM LOAD:** 250 kg.



Discos y barra no incluidos.  
Plates and bar not included.

## 10208

### JAULA DE SENTADILLA CON POLEA

SQUAT CAGE WITH PULLEY

- Fabricado en tubo de acero de 60 x 60 x 2 mm.
- Barra de dominadas multiagarre.
- Clavijas superiores e inferiores para bandas de resistencia.
- Soporte para fondos de tríceps.
- Soportes J para sentadilla.
- Soporte de seguridad para sentadilla.
- Polea alta y baja.
- Incluye agarre de polea alta.
- Incluye agarre recto para polea baja.
- Almacenaje para barras.
- Trunk blaster.
- Made with steel tubing of 60 x 60 x 2 mm.
- Multi-grip pull up bar.
- Upper and lower hooks for resistance bands.
- Triceps dips support.
- Squat J supports.
- Squat safety support.
- High and low pulley.
- High pulley grip is included.
- Straight grip for low pulley is included.
- Bars storage.
- Trunk blaster.

**DIMENSIONES | DIMENSIONS:** 205 x 121.5 / 141.5 x 213.5 cm. | **PESO | WEIGHT:** 138 kg.  
**CARGA MAX. POLEA | MAX LOAD PULLEY:** 150 kg. | **CARGA MÁXIMA | MAXIMUM LOAD:** 300 kg.



## 10200

### RACK DE SENTADILLAS ROOT R1

SQUAT RACK ROOT R1

- Rack regulable que permite realizar diferentes tipos de ejercicios.
- Fabricado en tubo de acero 75 x 75 mm y 3 mm de grosor con terminación en epoxi color negro.
- Bases de apoyo engomadas para evitar desgaste en el material.
- Adjustable rack that allows different types of exercises.
- Made of 75 x 75 mm steel tube and 3 mm thick with black epoxy finish.
- Adhesive support bases to avoid wear on the material.

**DIMENSIONES | DIMENSIONS:** 183 x 127 x 229 cm. | **PESO | WEIGHT:** 95 kg. | **CARGA MÁXIMA | MAXIMUM LOAD:** 250 kg.



## 10215

### SOPORTE SENTADILLAS INDIVIDUALES BLACK

BLACK INDIVIDUAL SQUAT SUPPORTS

- Estructura resistente construida en tubo acero de alta calidad de 60 x 60 x 1.5 mm.
- Tapas de goma en la base para mayor fijación y seguridad.
- Ocupa poco espacio.
- Si se complementa con un banco también permite trabajar pecho.
- Resistant structure built in high quality steel tube of 60 x 60 x 1.5 mm.
- Rubber caps on the base for better fixation and safety.
- Occupies little space.
- If complemented with a bench it also allows to work chest.

DIMENSIONES | DIMENSIONS: 62 x 49 x 126 cm. | PESO | WEIGHT: 45 kg. | CARGA MÁXIMA | MAXIMUM LOAD: 150 kg.



## 105307

### SOPORTES DE SENTADILLAS INDIVIDUALES

INDIVIDUAL SQUAT SUPPORT

- Rack fabricado en acero con terminación en negro.
- Barras verticales regulables en altura.
- Discos y barra no incluidos.
- Rack made of steel with black finish.
- Vertical bars adjustable in height.
- Discs and bars not included.

DIMENSIONES | DIMENSIONS: 56 x 51 x 105/180 cm.

PESO | WEIGHT: 8 kg.

Discos y barra no incluidos.  
Plates and bar not included.



## 10219

### RACK DE SENTADILLAS BASIC

SQUAT RACK BASIC

- Estructura resistente construida en tubo acero de alta calidad de 60 x 60 x 2 mm.
- Incluye espacio para almacenamiento de discos y soporte de seguridad.
- Discos y barra no incluidos.
- Sturdy frame constructed from high quality 60 x 60 x 2 mm steel tubing.
- Includes storage space for discs and safety support.
- Plates and bar are not included.

DIMENSIONES | DIMENSIONS: 150 x 155 x 160 cm. | PESO | WEIGHT: 46 kg. | CARGA MÁXIMA | MAXIMUM LOAD: 200 kg.

Discos y barra no incluidos.  
Plates and bar not included.



Discos y barra no incluidos.  
Plates and bar not included.

## 10216

### RACK DE SENTADILLA BLACK

BLACK SQUAT RACK

- Estructura resistente construida en tubo acero de alta calidad de 60 x 60 x 2 mm.
- Incluye espacio para almacenamiento de discos y soporte de seguridad.
- Dispone de barra de dominadas y soporte para sentadillas permitiendo múltiples ejercicios.
- Sturdy frame constructed from high quality 60 x 60 x 2 mm steel tubing.
- Includes storage space for discs and safety support.
- It has a pull-up bar and squat rack allowing for multiple exercises.

DIMENSIONES | DIMENSIONS: 163 x 130 x 216 cm. | PESO | WEIGHT: 79 kg. | CARGA MÁXIMA | MAXIMUM LOAD: 200 kg.



## WA1

### ESPALDERA

WALL BAR

- Uso doméstico. Espaldera con estructura de acero, acabado epoxi negro y travesaños de madera.
- Domestic use. Trellis with steel structure, black epoxy finish and wooden crossbars.

DIMENSIONES | DIMENSIONS: 80 x 18.5 x 222 cm.

PESO | WEIGHT: 22 kg.

PESO MÁX USUARIO. | MAX USER WEIGHT: 150 kg.





## H1 FUNCIONAL TRAINER FUNCTIONAL TRAINER

Uso doméstico. Permite realizar una amplia variedad de ejercicios, gracias a sus poleas regulables en altura y giratorias.

- Doble agarre.
- Polea fabricada en aluminio.
- Incluye agarres estribo.
- Parte frontal en espejo.
- Construcción en tubo de acero.
- Estructura recubierta con pintura en polvo de color negro. Los elementos pintados electrostáticamente en color rojo están fabricados en aluminio. Especialmente diseñado para ser anclado a la pared lo que permite ahorrar espacio. Transmisión por cable ajustable de 1 a 26 grados.
- Barra guía de acero.
- Placas de acero pintadas en negro.
- Grosor de los tubos 100 x 50 x 3 mm.
- Barra vertical reguladora de poleas 40 x 40 mm. regulable en 26 posiciones de altura.
- Diámetro de las ruedas de polea 7 cm.
- 20 placas de acero de 2.5 kg cada una.
- Cable de 9.5 m.
- Ratio usando 2 cables: 1:2.
- Ratio usando 1 cable: 1:4.

For home use. Allows a wide variety of exercises, thanks to its height-adjustable and rotating pulleys.

- Double grip.
- Pulley made of aluminium.
- Includes stirrup grips.
- Mirrored front.
- Steel tube construction.
- Structure coated with black powder paint. The red aluminium elements are electrostatically painted. They have been specially designed to be anchored to the wall and save space. Adjustable cable drive from 1 to 26 degrees.
- Steel guide bar.
- Black painted steel plates.
- Tube thickness 100 x 50 x 3 mm.
- The vertical bar for adjusting pulleys measure 40 x 40 mm. and it's adjustable in 26 height positions.
- The diameter of the pulley wheels is 7 cm.
- 20 steel plates of 2.5 kg each.
- 9.5 m cable.
- Ratio using 2 cables: 1:2.
- Ratio using 1 cable: 1:4.

DIMENSIONES | DIMENSIONS:  
63.5 x 16.5 x 198 cm.

PESO | WEIGHT:  
103 kg.

CARGA DE PLACAS / PLATE LOADING:  
50 kg.

PESO MÁX USUARIO. | MAX USER WEIGHT:  
150 kg.



## BK179B MULTIESTACIÓN PRENSA MULTI-STATION / LEG PRESS

- Estructura construida en tubo de acero de 2 mm. de espesor.
- Los asientos y los respaldos están fabricados con placas de madera por presión de 200 toneladas y esponja con regeneración.
- Agarre antideslizante y ergonómico.
- The structure is built in 2 mm steel tube.
- Upholstery are made of 200-tonne pressure-treated and sponge with regeneration.
- Non-slip and ergonomic grip.

DIMENSIONES | DIMENSIONS:  
242 x 226 x 213 cm.

CARGA DE PLACAS / PLATE LOADING:  
90 kg.

PESO | WEIGHT:  
315 kg.

PESO MÁX USUARIO. | MAX USER WEIGHT:  
150 kg.

## B2 BANCO REGULABLE REGULABLE BENCH

- Uso doméstico. Imprescindible para entrenamiento muscular en casa, con 7 posiciones para el respaldo y 3 posiciones para el asiento.

- Domestic use. Essential for muscle training at home, with 7 positions for the backrest and 3 positions for the seat.

DIMENSIONES | DIMENSIONS:  
126 x 41.5 x 115 cm.

PESO | WEIGHT:  
23.5 kg.

PESO MÁX USUARIO. | MAX USER WEIGHT:  
150 kg.



# SERIES PL25

Introducimos a nuestro catálogo la nueva línea profesional de plate load, la serie PL25. Una maquinaria de fuerza diseñada para los usuarios más exigentes. Lleva tus entrenamientos al límite de una forma totalmente eficiente y cómoda en cada movimiento gracias a su biomecánica perfectamente estudiada al detalle. La nueva PL25 muestra una estructura robusta y duradera fabricada en tubo de acero cuadrado de altas calidades capaz de soportar cualquier intensidad de entrenamiento. Además, presenta detalles como tapizado antibacteriano e ignífugo o ajustes específicos para adaptarse perfectamente a la movilidad y cuerpo de cada usuario. Un acierto seguro para equipar tu sala o centro de musculación.

## CARACTERÍSTICAS TÉCNICAS

- Fabricada en tubo cuadrado de acero Q235 de 3 mm de espesor.
- Estructura con pintura en polvo para una fijación total y una alta resistencia.
- Rodamientos industriales y tornillería de alta calidad.
- Portadiscos de carga en acero inoxidable.
- Configuración de la estructura en ángulo recto para garantizar una perfecta adaptación estructural.
- Biomecánica de máquina diseñada especialmente para permitir la accesibilidad a cualquier tipo de usuario.
- Tapizado con relleno de PU, antibacteriano e ignífugo.
- Asientos, respaldos y ajustes acolchados regulables que permiten adaptar la máquina al usuario.
- Agarres cómodos recubiertos de goma no porosa. Ofrecen una muy buena sensación de agarre y seguridad al contacto.
- Pictograma explicativo sobre la postura correcta para la realización del ejercicio y los músculos implicados en el mismo.
- Tacos de PVC blandos antideslizantes en su base.

We introduce to our catalog the new professional plate loading line, the PL25 series. A strength machinery designed for the most demanding users. Take your workouts to the limit in a totally efficient and comfortable way in every movement thanks to its biomechanics perfectly studied in detail. The new PL25 shows a robust and durable structure made of high-quality square steel tube capable of withstanding any training intensity. In addition, it presents details such as antibacterial and fireproof upholstery or specific adjustments to perfectly adapt to the mobility and body of each user. A sure hit to equip your room or weight center.

## TECHNICAL CHARACTERISTICS

- Made of 3 mm thick Q235 steel square tube.
- Powder-coated structure for total fixation and high resistance.
- Industrial bearings and high quality screws.
- Stainless steel loading disc holders.
- Configuration of the structure at right angles to guarantee a perfect structural adaptation.
- Machine biomechanics specially designed to allow accessibility to any type of user.
- Upholstered with PU filling, antibacterial and fire retardant.
- Adjustable seats, backrests and padded adjustments allow the machine to be adapted to the user.
- Non-porous rubber coated comfort grips. They offer a very good feeling of grip and security upon contact.
- Explanatory pictogram on the correct posture to perform the exercise and the muscles involved in it.
- Soft non-slip PVC studs on the base.

**1** Estructura en acero Q235 de 3 mm.  
Structure made of 3 mm Q235 steel.

**2** Portadiscos de carga en acero inoxidable.  
Stainless steel loading disc holders.

**3** Tapizado con relleno de PU, antibacteriano e ignífugo.  
Upholstered with PU filling, antibacterial and fire retardant.

**4** Asientos, respaldos y ajustes acolchados regulables  
Adjustable seats, backrests and padded adjustments.

**5** Agarres cómodos recubiertos de goma no porosa.  
Non-porous rubber coated comfort grips.

**6** Rodamientos industriales y tornillería de alta calidad.  
Industrial bearings and high quality screws.



# SERIES PL25



**PL2540**  
PRESS DE PECHO VERTICAL CON REGULACIÓN  
VERTICAL CHEST PRESS WITH REGULATION

DIMENSIONES | DIMENSIONS: 156 x 157 x 147.2 cm. | 
 PESO | WEIGHT: 155 kg. | 
 CARGA MAX. DISCOS | MAX DISC LOAD: 200 kg.



**PL2564**  
PRESS DE PECHO INCLINADO CON REGULACIÓN  
INCLINED CHEST PRESS WITH REGULATION

DIMENSIONES | DIMENSIONS: 200 x 174 x 147.2 cm. | 
 PESO | WEIGHT: 155 kg. | 
 CARGA MAX. DISCOS | MAX DISC LOAD: 200 kg.



**PL2563**  
PRESS DE HOMBROS CON REGULACION  
SHOULDER PRESS WITH REGULATION

DIMENSIONES | DIMENSIONS: 161 x 157 x 147.2 cm. | 
 PESO | WEIGHT: 155 kg. | 
 CARGA MAX. DISCOS | MAX DISC LOAD: 200 kg.



**PL25.050**  
BANCO DE PRESS DE BANCA TOTAL 3 EN 1  
TOTAL BENCH PRESS 3 IN 1

DIMENSIONES | DIMENSIONS: 205 x 125 x 140 cm.



**PL25.302**  
MAQUINA DE HOMBROS TOTAL 3 EN 1  
TOTAL SHOULDER MACHINE 3 IN 1

DIMENSIONES | DIMENSIONS: 150 x 140 x 155 cm. | 
 PESO | WEIGHT: 130 kg.

- CARGA MAX. DISCOS PRESS MILITAR | MAX. MILITARY PRESS DISCS LOAD: 120 kg.
- CARGA MAX. DISCOS APERTURAS SETANDAS | MAX. LOAD SEATED OPENINGS DISCS: 200 kg.



**PL25.301**  
BRAZOS TOTAL 2 EN 1  
TOTAL ARMS 2 IN 1

DIMENSIONES | DIMENSIONS: 144.5 x 111.2 x 119.5 cm. | 
 PESO | WEIGHT: 60 kg. | 
 CARGA MAX. DISCOS | MAX DISC LOAD: 240 kg.



**PL2541**  
PRESS DE BANCA HORIZONTAL  
HORIZONTAL BENCH PRESS

DIMENSIONES | DIMENSIONS: 175 x 173 x 111 cm. | PESO | WEIGHT: 96 kg. | CARGA MAX. DISCOS | MAX DISC LOAD: 200 kg.



**PL25.103**  
PRESS DE BANCA HORIZONTAL CON REGULACIÓN  
HORIZONTAL BENCH PRESS WITH REGULATION

DIMENSIONES | DIMENSIONS: 175 x 180 x 120 cm. | PESO | WEIGHT: 110 kg. | CARGA MAX. DISCOS | MAX DISC LOAD: 240 kg.



**PL25.110**  
PRESS DE PECHO DE PIE  
STANDING VERTICAL CHEST PRESS

DIMENSIONES | DIMENSIONS: 146 x 125 x 182 cm. | PESO | WEIGHT: 230 kg. | CARGA MAX. DISCOS | MAX DISC LOAD: 240 kg.



**PL2542**  
PRESS DE PECHO VERTICAL  
VERTICAL CHEST PRESS

DIMENSIONES | DIMENSIONS: 130 x 184 x 186 cm. | PESO | WEIGHT: 152 kg. | CARGA MAX. DISCOS | MAX DISC LOAD: 250 kg.



**PL2543**  
PRESS DE PECHO INCLINADO  
INCLINE CHEST PRESS

DIMENSIONES | DIMENSIONS: 164 x 90 x 193.7 cm. | PESO | WEIGHT: 147 kg. | CARGA MAX. DISCOS | MAX DISC LOAD: 250 kg.



**PL2544**  
PRESS DE PECHO DECLINADO  
DECLINING CHEST PRESS

DIMENSIONES | DIMENSIONS: 120 x 188 x 180 cm. | PESO | WEIGHT: 155 kg. | CARGA MAX. DISCOS | MAX DISC LOAD: 250 kg.



**PL2545**  
**APERTURAS INCLINADAS**  
 INCLINE PEC FLY

**DIMENSIONES | DIMENSIONS:** 174 x 165 x 119 cm. | **PESO | WEIGHT:** 105 kg. | **CARGA MAX. DISCOS | MAX DISC LOAD:** 250 kg.



**PL25.102**  
**APERTURAS INCLINADAS PRO+**  
 INCLINE PEC FLY PRO+

**DIMENSIONES | DIMENSIONS:** 160 x 175/230 x 120 cm. | **PESO | WEIGHT:** 105 kg. | **CARGA MAX. DISCOS | MAX DISC LOAD:** 240 kg.



**PL2546**  
**PRESS DE PECHO SUPER INCLINADO**  
 SUPER INCLINE CHEST PRESS

**DIMENSIONES | DIMENSIONS:** 130 x 169 x 153 cm. | **PESO | WEIGHT:** 130 kg. | **CARGA MAX. DISCOS | MAX DISC LOAD:** 250 kg.



**PL2547**  
**PRESS DE PECHO VERTICAL ABIERTO**  
 VERTICAL WIDE CHEST PRESS

**DIMENSIONES | DIMENSIONS:** 118 x 200 x 172 cm. | **PESO | WEIGHT:** 158.5 kg. | **CARGA MAX. DISCOS | MAX DISC LOAD:** 250 kg.



**PL2537**  
**CONTRACCIÓN DE PECHO**  
 PEC DECK

**DIMENSIONES | DIMENSIONS:** 120 x 126 x 155 cm. | **PESO | WEIGHT:** 79.5 kg. | **CARGA MAX. DISCOS | MAX DISC LOAD:** 150 kg.



**PL2554**  
**POLEA ALTA**  
 WIDE PULLDOWN

**DIMENSIONES | DIMENSIONS:** 176 x 118 x 201 cm. | **PESO | WEIGHT:** 145 kg. | **CARGA MAX. DISCOS | MAX DISC LOAD:** 250 kg.



**PL2551**  
POLEA ALTA INVERTIDA  
ISO FRONT LAT PULLDOWN

DIMENSIONES | DIMENSIONS: 183 x 139 x 199 cm. | PESO | WEIGHT: 156 kg. | CARGA MAX. DISCOS | MAX DISC LOAD: 250 kg.



**PL2552**  
POLEA ALTA AG CRUZADO  
ISOLATERAL HIGH ROW

DIMENSIONES | DIMENSIONS: 161 x 153 x 201 cm. | PESO | WEIGHT: 159 kg. | CARGA MAX. DISCOS | MAX DISC LOAD: 250 kg.



**PL2560**  
DUAL POLEA ALTA INVERTIDA/PRESS DE PECHO INCLINADO  
DUAL ISOLATERAL CHEST/BACK

DIMENSIONES | DIMENSIONS: 207 x 169 x 203 cm. | PESO | WEIGHT: 187.5 kg. | CARGA MAX. DISCOS | MAX DISC LOAD: 250 kg.



**PL2584**  
JALON DORSAL CON BARRA  
LAT PULLDOWN BAR TRAINER

DIMENSIONES | DIMENSIONS: 162 x 119 x 200 cm. | PESO | WEIGHT: 196 kg. | CARGA MAX. DISCOS | MAX DISC LOAD: 250 kg.



**PL2559**  
REMO SUPER  
SUPER ROWING

DIMENSIONES | DIMENSIONS: 149 x 143 x 138 cm. | PESO | WEIGHT: 120 kg. | CARGA MAX. DISCOS | MAX DISC LOAD: 250 kg.



**PL25.056**  
REMO DORIAN  
DORIAN ROWING

DIMENSIONES | DIMENSIONS: 124 x 100 x 126 cm. | PESO | WEIGHT: 125 kg. | CARGA MAX. DISCOS | MAX DISC LOAD: 240 kg.



**PL2527**  
REMO BAJO AGARRE SUPINO  
LOW ROW SUPINE GRIP

DIMENSIONES | DIMENSIONS: 147 x 163 x 214 cm. | PESO | WEIGHT: 160 kg. | CARGA MAX. DISCOS | MAX DISC LOAD: 250 kg.



**PL2555**  
REMO BAJO AGARRE PRONO  
LOW ROW PRONE GRIP

DIMENSIONES | DIMENSIONS: 127 x 138 x 167 cm. | PESO | WEIGHT: 130 kg. | CARGA MAX. DISCOS | MAX DISC LOAD: 250 kg.



**PL2558**  
PULLOVER  
PULLOVER

DIMENSIONES | DIMENSIONS: 168 x 192 x 183 cm. | PESO | WEIGHT: 160 kg. | CARGA MAX. DISCOS | MAX DISC LOAD: 250 kg.



**PL2592**  
REMO DE PIE SIN APOYO AL PECHO  
STAND ROW WITHOUT CHEST SUPPORT

DIMENSIONES | DIMENSIONS: 179 x 155 x 242 cm. | PESO | WEIGHT: 156 kg. | CARGA MAX. DISCOS | MAX DISC LOAD: 200 kg.



**PL25.066**  
REMO EN PUNTA CON APOYO AL PECHO  
T-BAR ROW WITH SUPPORT

DIMENSIONES | DIMENSIONS: 176 x 122 x 120 cm. | CARGA MAX. DISCOS | MAX DISC LOAD: 240 kg.



**PL25.053**  
REMO EN PUNTA SIN APOYO AL PECHO  
T-BAR ROW WITHOUT CHEST SUPPORT

DIMENSIONES | DIMENSIONS: 166 x 87 x 42.5 cm. | CARGA MAX. DISCOS | MAX DISC LOAD: 240 kg.





**PL25.514**  
**DUAL REMO/PESO MUERTO**  
 DUAL ROW/DEADLIFT

**DIMENSIONES | DIMENSIONS:** 200 x 115 x 110 cm. | **PESO | WEIGHT:** 130 kg. | **CARGA MAX. DISCOS | MAX DISC LOAD:** 240 kg.



**PL2590**  
**REMO INCLINADO CON APOYO**  
 INCLINED ROWING WITH SUPPORT

**DIMENSIONES | DIMENSIONS:** 162 x 172 x 113 cm. | **PESO | WEIGHT:** 165 kg. | **CARGA MAX. DISCOS | MAX DISC LOAD:** 350 kg.



**PL2562**  
**PRESS TRAS NUCA**  
 INCLINE SHOULDER PRESS

**DIMENSIONES | DIMENSIONS:** 141 x 186 x 189 cm. | **PESO | WEIGHT:** 145 kg. | **CARGA MAX. DISCOS | MAX DISC LOAD:** 250 kg.



**PL25.309**  
**PRESS TRAS NUCA REGULABLE**  
 BENCH ISO INCLINE SHOULDER PRESS

**DIMENSIONES | DIMENSIONS:** 146 x 180 x 185 cm. | **PESO | WEIGHT:** 160 kg. | **CARGA MAX. DISCOS | MAX DISC LOAD:** 240 kg.



**PL2591**  
**DUAL PRESS DE HOMBROS DE PIE/JALÓN DORSAL**  
 DUAL STANDING SHOULDER PRESS/LAT PULLDOWN

**DIMENSIONES | DIMENSIONS:** 190 x 135 x 206 cm. | **PESO | WEIGHT:** 146 kg. | **CARGA MAX. DISCOS | MAX DISC LOAD:** 200 kg.



**PL2561**  
**PRESS DE HOMBROS**  
 SHOULDER PRESS

**DIMENSIONES | DIMENSIONS:** 144 x 189.5 x 156 cm. | **PESO | WEIGHT:** 196 kg. | **CARGA MAX. DISCOS | MAX DISC LOAD:** 250 kg.



## PL2538

### VUELOS DE PIE

STANDING LATERAL RAISE

**DIMENSIONES | DIMENSIONS:** 120 x 112 x 135 cm. | 
 **PESO | WEIGHT:** 75 kg. | 
 **CARGA MAX. DISCOS | MAX DISC LOAD:** 150 kg.



## PL25.065

### DELTOIDES POSTERIOR

UPRIGHT DELTOID

**DIMENSIONES | DIMENSIONS:** 170 x 76/254 x 116 cm. | 
 **PESO | WEIGHT:** 125 kg. | 
 **CARGA MAX. DISCOS | MAX DISC LOAD:** 240 kg.



## PL25.030

### CURL DE BICEPS ALTERNO

ALTERNATE BICEPS CURL

**DIMENSIONES | DIMENSIONS:** 95 x 175 x 129 cm. | 
 **CARGA MAX. DISCOS | MAX DISC LOAD:** 240 kg.



## PL25.311

### CURL DE BICEPS UNILATERAL

UNILATERAL BICEPS CURL

**DIMENSIONES | DIMENSIONS:** 105 x 145 x 102 cm. | 
 **PESO | WEIGHT:** 90 kg. | 
 **CARGA MAX. DISCOS | MAX DISC LOAD:** 240 kg.



## PL2536

### FONDOS DE TRICEPS

TRICEPS DIPS

**DIMENSIONES | DIMENSIONS:** 169 x 159 x 106 cm. | 
 **PESO | WEIGHT:** 125 kg. | 
 **CARGA MAX. DISCOS | MAX DISC LOAD:** 250 kg.



## PL2531

### CURL DE BÍCEPS

BICEPS CURL

**DIMENSIONES | DIMENSIONS:** 151 x 146 x 147 cm. | 
 **PESO | WEIGHT:** 98 kg. | 
 **CARGA MAX. DISCOS | MAX DISC LOAD:** 125 kg.



**PL25.001**  
EXTENSIÓN DE CUÁDRICEPS UNILATERAL  
QUADRICEPS EXTENSION

DIMENSIONES | DIMENSIONS: 160 x 154 x 119 cm. | PESO | WEIGHT: 135 kg. | CARGA MAX. DISCOS | MAX DISC LOAD: 240 kg.



**PL25.002**  
FEMORAL TUMBADO UNILATERAL  
LYING LEG CURL

DIMENSIONES | DIMENSIONS: 180 x 135 x 100 cm. | PESO | WEIGHT: 128 kg. | CARGA MAX. DISCOS | MAX DISC LOAD: 240 kg.



**PL25.004**  
FEMORAL DE PIE UNILATERAL  
KNEELING LEG CURL

DIMENSIONES | DIMENSIONS: 130 x 120 x 131 cm. | CARGA MAX. DISCOS | MAX DISC LOAD: 100 kg.



**PL25.500**  
PRENSA INCLINADA 45° PRO+  
45° INCLINED PRESS PRO+

DIMENSIONES | DIMENSIONS: 217 x 150 x 149.5 cm. | PESO | WEIGHT: 286 kg. | CARGA MAX. DISCOS | MAX DISC LOAD: 480 kg.



**PL2532**  
ANTEBRAZOS TOTAL  
TOTAL FOREARMS

DIMENSIONES | DIMENSIONS: 168 x 160 x 133 cm. | PESO | WEIGHT: 135 kg. | CARGA MAX. DISCOS | MAX DISC LOAD: 200 kg.



**PL25.500A**  
PRENSA INCLINADA 45° MULTIPLANO PRO+  
MULTIANGLED INCLINED PRESS 45° PRO+

DIMENSIONES | DIMENSIONS: 217 x 150 x 149.5 cm. | PESO | WEIGHT: 286 kg. | CARGA MAX. DISCOS | MAX DISC LOAD: 480 kg.



**PL2572**  
HACK SQUAT/JACA  
HACK SQUAT

DIMENSIONES | DIMENSIONS: 220 x 200 x 127 cm. | PESO | WEIGHT: 186 kg. | CARGA MAX. DISCOS | MAX DISC LOAD: 300 kg.



**PL25.507**  
JACA PÉNDULO PRO+  
TOTAL PENDULUM SQUAT PRO+

DIMENSIONES | DIMENSIONS: 220 x 130 x 156 cm. | PESO | WEIGHT: 200 kg. | CARGA MAX. DISCOS | MAX DISC LOAD: 240 kg.



**PL2520**  
POWER SQUAT  
POWER SQUAT

DIMENSIONES | DIMENSIONS: 185 x 158 x 154 cm. | PESO | WEIGHT: 205 kg. | CARGA MAX. DISCOS | MAX DISC LOAD: 250 kg.



**PL25.503**  
JACA PÉNDULO ELITE  
PENDULUM SQUAT ELITE

DIMENSIONES | DIMENSIONS: 171 x 98 x 156 cm. | PESO | WEIGHT: 135 kg. | CARGA MAX. DISCOS | MAX DISC LOAD: 240 kg.



**PL25.505**  
JACA V-SQUAT DUAL  
DUAL HACK V-SQUAT

DIMENSIONES | DIMENSIONS: 173 x 97.5 x 184 cm. | PESO | WEIGHT: 117 kg. | CARGA MAX. DISCOS | MAX DISC LOAD: 250 kg.



**PL2571**  
JACA V-SQUAT  
HACK V-SQUAT

DIMENSIONES | DIMENSIONS: 245 x 130 x 158 cm. | PESO | WEIGHT: 220 kg. | CARGA MAX. DISCOS | MAX DISC LOAD: 450 kg.



**PL25.015**  
PRENSA HORIZONTAL  
HORIZONTAL LEG PRESS

DIMENSIONES | DIMENSIONS: 182 x 156 x 142 cm. | PESO | WEIGHT: 243 kg. | CARGA MAX. DISCOS | MAX DISC LOAD: 200 kg.



**PL25.506**  
PRENSA HORIZONTAL UNI-BI-LATERAL  
HORIZONTAL LEG PRESS (UNILATERAL)

DIMENSIONES | DIMENSIONS: 181 x 161 x 142 cm. | PESO | WEIGHT: 235 kg. | CARGA MAX. DISCOS | MAX DISC LOAD: 240 kg.



**PL25.017**  
JACA PALANCA  
HACK PRESS

DIMENSIONES | DIMENSIONS: 220 x 132 x 145 cm. | CARGA MAX. DISCOS | MAX DISC LOAD: 150 kg.



**PL2515**  
PRENSA HORIZONTAL UNILATERAL  
HORIZONTAL LEG PRESS

DIMENSIONES | DIMENSIONS: 177 x 169 x 150 cm. | PESO | WEIGHT: 145 kg. | CARGA MAX. DISCOS | MAX DISC LOAD: 400 kg.



**PL25.006**  
PRENSA VERTICAL PRO+  
VERTICAL LEG PRESS PRO+

DIMENSIONES | DIMENSIONS: 198 x 128 x 193 cm. | PESO | WEIGHT: 160 kg. | CARGA MAX. DISCOS | MAX DISC LOAD: 240 kg.



**PL2506**  
PRENSA VERTICAL ELITE  
VERTICAL LEG PRESS ELITE

DIMENSIONES | DIMENSIONS: 157.5 x 185 x 201 cm. | PESO | WEIGHT: 210 kg. | CARGA MAX. DISCOS | MAX DISC LOAD: 400 kg.



**PL25.011**  
GEMELO/SENTADILLA  
SQUAT CALF

DIMENSIONES | DIMENSIONS: 132 x 142 x 180 cm. | PESO | WEIGHT: 155 kg. | CARGA MAX. DISCOS | MAX DISC LOAD: 240 kg.



**PL2583**  
SENTADILLA CON CINTURÓN ELITE  
BELT SQUAT ELITE

DIMENSIONES | DIMENSIONS: 225 x 175 x 159 cm. | PESO | WEIGHT: 208 kg. | CARGA MAX. DISCOS | MAX DISC LOAD: 400 kg.



**PL25.502**  
SENTADILLA CON CINTURÓN PRO+  
BELT SQUAT PRO+

DIMENSIONES | DIMENSIONS: 146 x 102 x 112 cm. | PESO | WEIGHT: 78 kg. | CARGA MAX. DISCOS | MAX DISC LOAD: 390 kg.



**PL2526**  
SQUAT HIGH PULL  
SQUAT HIGH PULL

DIMENSIONES | DIMENSIONS: 183 x 163.5 x 104 cm. | PESO | WEIGHT: 95 kg. | CARGA MAX. DISCOS | MAX DISC LOAD: 250 kg.



**PL2596**  
GLUTEO SENTADO/ABDUCTOR  
SEATED GLUTE/ABDUCTOR

DIMENSIONES | DIMENSIONS: 168 x 138 x 141 cm. | PESO | WEIGHT: 132 kg. | CARGA MAX. DISCOS | MAX DISC LOAD: 250 kg.



**PL2595**  
PATADA DE GLUTEO PRONO  
GLUTE PRESS MACHINE PRONE

DIMENSIONES | DIMENSIONS: 221 x 119 x 168 cm. | PESO | WEIGHT: 105 kg. | CARGA MAX. DISCOS | MAX DISC LOAD: 125 kg.



**PL25.504**  
**GEMELO BURRO**  
 DONKEY CALF RAISE

DIMENSIONES | DIMENSIONS: 150.5 x 80.5 x 156 cm. | CARGA MAX. DISCOS | MAX DISC LOAD: 240 kg.



**PL25.013**  
**GEMELO SENTADO PRO+**  
 SEATED CALF RAISE

DIMENSIONES | DIMENSIONS: 142 x 61 x 96 cm. | PESO | WEIGHT: 90 kg. | CARGA MAX. DISCOS | MAX DISC LOAD: 100 kg.



**PL25.014**  
**TIBIAL**  
 TIBIAL

DIMENSIONES | DIMENSIONS: 37 x 82 x 30 cm. | CARGA MAX. DISCOS | MAX DISC LOAD: 40 kg.



**PL2580**  
**BANCO SENTADILLA SISSY**  
 SISSY SQUAT BENCH

DIMENSIONES | DIMENSIONS: 100 x 56 x 51 cm. | PESO | WEIGHT: 42 kg. | PESO MÁXIMO | MAXIMUM WEIGHT: 200 kg.



**PL25.021**  
**ABDOMINAL/OBLICUOS**  
 ABDOMINAL/OBLIQUE CRUNCH

DIMENSIONES | DIMENSIONS: 98 x 135 x 161 cm. | PESO | WEIGHT: 162 kg. | CARGA MAX. DISCOS | MAX DISC LOAD: 240 kg.



**PL2581**  
**BANCO LUMBAR REGULABLE PRO+**  
 ADJUSTABLE LUMBAR BENCH PRO+

DIMENSIONES | DIMENSIONS: 152 x 74 x 79 cm. | PESO | WEIGHT: 59 kg. | CARGA MAX. DISCOS | MAX DISC LOAD: 200 kg.

# SERIES PL40

## PL4007 PRESS VERTICAL

CHEST PRESS

 DIMENSIONES | DIMENSIONS: 137 x 162 x 174 cm. |  PESO | WEIGHT: 153 kg.

 CARGA MAX. DISCOS | MAX LOAD PLATES: 200 kg.



## PL4008 PRESS DECLINADO

WIDE CHEST PRESS

 DIMENSIONES | DIMENSIONS: 143 x 154 x 176 cm. |  PESO | WEIGHT: 180 kg.

 CARGA MAX. DISCOS | MAX LOAD PLATES: 200 kg.



## PL4001 PRESS INCLINADO

INCLINE CHEST PRESS

 DIMENSIONES | DIMENSIONS: 125 x 168 x 170 cm. |  PESO | WEIGHT: 153 kg.

 CARGA MAX. DISCOS | MAX LOAD PLATES: 200 kg.





**PL4004**  
**PRESS DE HOMBROS**  
 SHOULDER PRESS

DIMENSIONES | DIMENSIONS: 117 x 135 x 154 cm. | 
 PESO | WEIGHT: 140 kg. | 
 CARGA MAX. DISCOS | MAX LOAD PLATES: 200 kg.



**PL4009**  
**REMO DORIAN**  
 ROW

DIMENSIONES | DIMENSIONS: 150 x 142 x 134 cm. | 
 PESO | WEIGHT: 152 kg. | 
 CARGA MAX. DISCOS | MAX LOAD PLATES: 200 kg.



**PL4003**  
**JALÓN DORSAL**  
 LAT PULLDOWN

DIMENSIONES | DIMENSIONS: 182 x 131 x 199 cm. | 
 PESO | WEIGHT: 141 kg. | 
 CARGA MAX. DISCOS | MAX LOAD PLATES: 200 kg.



**PL4002**  
**REMO BAJO**  
 LOW ROW

DIMENSIONES | DIMENSIONS: 139 x 128 x 165 cm. | 
 PESO | WEIGHT: 146 kg. | 
 CARGA MAX. DISCOS | MAX LOAD PLATES: 200 kg.



**PL4005**  
**PRESA INCLINADA 45° PALANCA**  
 LEVER 45° LEG PRESS

DIMENSIONES | DIMENSIONS: 210 x 160 x 156 cm. | 
 PESO | WEIGHT: 194 kg. | 
 CARGA MAX. DISCOS | MAX LOAD PLATES: 400 kg.



**PL4024**  
SENTADILLA CON CINTURÓN  
BELT SQUAT

DIMENSIONES | DIMENSIONS: 182.2 x 108.2 x 127.3 cm. | PESO | WEIGHT: 102 kg. | CARGA MAX. DISCOS | MAX LOAD PLATES: 200 kg.



**PL4023**  
HIP THRUST DE PIE  
STANDING HIP THRUST

DIMENSIONES | DIMENSIONS: 133.6 x 135.4 x 147.7 cm. | PESO | WEIGHT: 93 kg. | CARGA MAX. DISCOS | MAX LOAD PLATES: 200 kg.



**PL4019**  
ABDUCTOR DE PIE  
STANDING ABDUCTOR

DIMENSIONES | DIMENSIONS: 176 x 113 x 151 cm. | PESO | WEIGHT: 72 kg. | CARGA MAX. DISCOS | MAX LOAD PLATES: 200 kg.



**PL4012**  
FONDOS DE TRÍCEPS  
SEATED DIP

DIMENSIONES | DIMENSIONS: 167 x 161 x 100 cm. | PESO | WEIGHT: 137 kg. | CARGA MAX. DISCOS | MAX LOAD PLATES: 200 kg.



**PL4013**  
CURL DE BÍCEPS  
BICEPS CURL

DIMENSIONES | DIMENSIONS: 115 x 136 x 102 cm. | PESO | WEIGHT: 118 kg. | CARGA MAX. DISCOS | MAX LOAD PLATES: 100 kg.



JOIN US IN  
**VEGAS**  
 AS WE CELEBRATE

**60**



**YEARS**

**OCT. 10-13 24**



PATROCINADOR OFICIAL MR. OLYMPIA 2024  
 OFFICIAL SPONSOR MR. OLYMPIA 2024



SPECIAL SERIES  
**PL80**



**PL8042**  
**PRESS DE PECHO VERTICAL**  
 VERTICAL CHEST PRESS

 **DIMENSIONES | DIMENSIONS:** 158 x 101 x 184 cm. |
  **PESO | WEIGHT:** 175 kg. |
  **CARGA MAX. DISCOS | MAX LOAD PLATES:** 400 kg.



**PL8055**  
**PRESS INCLINADO**  
 INCLINED PRESS

 **DIMENSIONES | DIMENSIONS:** 173.5 x 96 x 134 cm. |
  **PESO | WEIGHT:** 135 kg. |
  **CARGA MAX. DISCOS | MAX LOAD PLATES:** 400 kg.



**PL8049**  
**PRESS DE HOMBROS**  
 SHOULDER PRESS

 **DIMENSIONES | DIMENSIONS:** 143.5 x 97 x 143.5 cm. |
  **PESO | WEIGHT:** 121 kg. |
  **CARGA MAX. DISCOS | MAX LOAD PLATES:** 400 kg.



**PL8044**  
CURL CONCENTRADO DE BÍCEPS  
BICEPS CURL

 DIMENSIONES | DIMENSIONS: 94 x 151 x 160 cm. |
  PESO | WEIGHT: 139 kg. |
  CARGA MAX. DISCOS | MAX LOAD PLATES: 400 kg.



**PL8053**  
EXTENSIÓN DE TRÍCEPS  
TRICEPS EXTENSION

 DIMENSIONES | DIMENSIONS: 94 x 151 x 158 cm. |
  PESO | WEIGHT: 139 kg. |
  CARGA MAX. DISCOS | MAX LOAD PLATES: 400 kg.



**PL8048**  
FONDOS TRÍCEPS  
SEATED TRICEPS DIP

 DIMENSIONES | DIMENSIONS: 135.5 x 175 x 104.5 cm. |
  PESO | WEIGHT: 120 kg. |
  CARGA MAX. DISCOS | MAX LOAD PLATES: 400 kg.



## PL8041

### REMO BAJO

LOW ROW

 DIMENSIONES | DIMENSIONS: 235 x 89 x 92 cm.
  PESO | WEIGHT: 136 kg.
  CARGA MAX. DISCOS | MAX LOAD PLATES: 400 kg.



## PL8040

### SQUAT LUNGE

SQUAT LUNGE

 DIMENSIONES | DIMENSIONS: 189 x 177.5 x 80 cm.
  PESO | WEIGHT: 95 kg.
  CARGA MAX. DISCOS | MAX LOAD PLATES: 400 kg.

## PL8052



### JALÓN DORSAL

LAT PULLDOWN

 DIMENSIONES | DIMENSIONS: 205.7 x 90 x 232 cm.
  PESO | WEIGHT: 168 kg.
  CARGA MAX. DISCOS | MAX LOAD PLATES: 400 kg.





**PL8051**  
EXTENSIÓN DE CUÁDRICEPS  
LEG EXTENSION

 DIMENSIONES | DIMENSIONS: 168 x 113 x 129 cm. | 
  PESO | WEIGHT: 97 kg. | 
  CARGA MAX. DISCOS | MAX LOAD PLATES: 400 kg.



**PL8056**  
FEMORAL TUMBADO  
LYING LEG CURL

 DIMENSIONES | DIMENSIONS: 194 x 105 x 75 cm. | 
  PESO | WEIGHT: 93 kg. | 
  CARGA MAX. DISCOS | MAX LOAD PLATES: 400 kg.



**PL8039**  
PRENSA INCLINADA 45°  
45° INCLINE LEG PRESS

 DIMENSIONES | DIMENSIONS: 229 x 137 x 151 cm. | 
  PESO | WEIGHT: 262 kg. | 
  CARGA MAX. DISCOS | MAX LOAD PLATES: 400 kg.



**PL8043**  
PRENSA DE PIERNAS HORIZONTAL  
HORIZONTAL LEG PRESS

 DIMENSIONES | DIMENSIONS: 251 x 171 x 145 cm. | 
  PESO | WEIGHT: 262 kg. | 
  CARGA MAX. DISCOS | MAX LOAD PLATES: 400 kg.

## SPECIAL SERIES

## PL30

Diseñada para realizar **DROP SET** o más conocida como serie descendente.

Designed to perform **DROP SET** or better known as descending series.

## SISTEMA DE MODIFICACIÓN DE CARGA

## LOAD MODIFICATION SYSTEM

- Sistema de carga de discos con selector que posibilita la elección entre 3 niveles distintos de tensión a la hora de ejecutar el ejercicio. Este mecanismo está diseñado para potenciar y experimentar una sensación de entrenamiento dinámica y continua. Entre sus tres posiciones encontramos una tensión baja, neutra y alta con una variación descendente o ascendente del 25% del peso cargado. Una característica inusual en el mercado y que da un carácter único a la línea PL30.
- Plate loading system with a selector that allows you to choose between 3 different levels of tension when performing the exercise. This mechanism is designed to enhance and experience a dynamic and continuous training sensation. Among its three positions we find low, neutral and high tension with a downward or upward variation of 25% of the loaded weight. An unusual feature on the market that gives a unique character to the PL30 line.



## PL3001

### PRESS DE PECHO VERTICAL

## CHEST PRESS

DIMENSIONES | DIMENSIONS: 195.6 x 109.7 x 117.8 cm. | PESO | WEIGHT: 101 kg. | CARGA MAX. DISCOS | MAX LOAD PLATES: 300 kg.



## PL3002

### REMO SUPER

## SUPER ROWING

DIMENSIONES | DIMENSIONS: 147 x 136.5 x 125 cm. | PESO | WEIGHT: 115 kg. | CARGA MAX. DISCOS | MAX LOAD PLATES: 300 kg.



## PL3003

### PRESS DE HOMBROS

## SHOULDER PRESS

DIMENSIONES | DIMENSIONS: 171.4 x 127.3 x 125.9 cm. | PESO | WEIGHT: 123 kg. | CARGA MAX. DISCOS | MAX LOAD PLATES: 300 kg.



## PL3006

### JALÓN DORSAL



## LAT PULLDOWN

DIMENSIONES | DIMENSIONS: 140.7 x 183.9 x 183 cm. | PESO | WEIGHT: 103.5 kg. | CARGA MAX. DISCOS | MAX LOAD PLATES: 300 kg.







**PL3008**  
PRENSA INCLINADA UNILATERAL DE PALANCA  
LEG PRESS

 DIMENSIONES | DIMENSIONS: 171 x 175 x 143.2 cm. |
  PESO | WEIGHT: 217 kg. |
  CARGA MAX. DISCOS | MAX LOAD PLATES: 500 kg.





**PL3010**  
PATADA DE GLÚTEO PRONO  
PRONE REAR KICK

 DIMENSIONES | DIMENSIONS: 128.2 x 142.2 x 122 cm. |
  PESO | WEIGHT: 90 kg. |
  CARGA MAX. DISCOS | MAX LOAD PLATES: 150 kg.





**PL3013**  
DUAL CUÁDRICEPS / FEMORAL TUMBADO  
DUAL QUADRICEPS / LYING LEG CURL

 DIMENSIONES | DIMENSIONS: 141.7 x 134.6 x 103.8 cm. |
  PESO | WEIGHT: 103.3 kg. |
  CARGA MAX. DISCOS | MAX LOAD PLATES: 150 kg.



**PL3015**  
SQUAT LUNGE  
SQUAT LUNGE

 DIMENSIONES | DIMENSIONS: 193.5 x 147.8 x 73.6 cm. |
  PESO | WEIGHT: 105.2 kg. |
  CARGA MAX. DISCOS | MAX LOAD PLATES: 300 kg.



**PL3016**  
ABDUCTOR DE PIE  
STANDING ABDUCTOR

 DIMENSIONES | DIMENSIONS: 152.2 x 144.2 x 97 cm. |
  PESO | WEIGHT: 111 kg. |
  CARGA MAX. DISCOS | MAX LOAD PLATES: 300 kg.

## SPECIAL SERIES

## PL10

PL10 SERIES



## PL1018

## PRENSA INCLINADA 45° UNI-BI-LATERAL

UNI-BI-LATERAL 45° INCLINED PRESS

DIMENSIONES | DIMENSIONS: 266 x 155 x 160 cm. | 
 PESO | WEIGHT: 440 kg. | 
 CARGA MAX. DISCOS | MAX LOAD PLATES: 480 kg.



## PL1009

## GEMELO 45°

CALF 45°

DIMENSIONES | DIMENSIONS: 174 x 120 x 116 cm. | 
 PESO | WEIGHT: 115 kg. | 
 CARGA MAX. DISCOS | MAX LOAD PLATES: 250 kg.



## PL1008

## PRENSA INCLINADA 45° PALANCA

LEVER 45° LEG PRESS

DIMENSIONES | DIMENSIONS: 266 x 176 x 147 cm. | 
 PESO | WEIGHT: 225 kg. | 
 CARGA MAX. DISCOS | MAX LOAD PLATES: 500 kg.



## PL1025

## HIP THRUSTER

HIP THRUSTER

DIMENSIONES | DIMENSIONS: 184 x 155 x 84.5 cm. | 
 PESO | WEIGHT: 105 kg. | 
 CARGA MAX. DISCOS | MAX LOAD PLATES: 240 kg.



## PL1008

## PRENSA INCLINADA 45° PALANCA

LEVER 45° LEG PRESS

DIMENSIONES | DIMENSIONS: 266 x 176 x 147 cm. | 
 PESO | WEIGHT: 225 kg. | 
 CARGA MAX. DISCOS | MAX LOAD PLATES: 500 kg.



## PL1015

## GLUTE DRIVE CON RODILLO

ROLLER GLUTE DRIVE

DIMENSIONES | DIMENSIONS: 162.5 x 125 x 81.5 cm. | 
 PESO | WEIGHT: 89 kg. | 
 CARGA MAX. DISCOS | MAX LOAD PLATES: 200 kg.



## PL1026

## BANCO HIP THRUSTER

HIP THRUSTER BENCH

DIMENSIONES | DIMENSIONS: 220 x 152 x 52 cm. | 
 PESO | WEIGHT: 125 kg.

## PL1024

## GLUTE DRIVE CON CINTURÓN

GLUTE DRIVE WITH BELT

DIMENSIONES | DIMENSIONS: 153 x 150 x 90 cm. | 
 PESO | WEIGHT: 92 kg. | 
 CARGA MAX. DISCOS | MAX LOAD PLATES: 180 kg.



**PL1028**  
PRENSA DE PIERNAS HORIZONTAL UNILATERAL  
HORIZONTAL UNILATERAL LEG PRESS

DIMENSIONES | DIMENSIONS: 230 x 212 x 153 cm. | PESO | WEIGHT: 318 kg. | CARGA MAX. DISCOS | MAX LOAD PLATES: 450 kg.



**PL1011**  
EXTENSIÓN DE CUÁDRICEPS UNILATERAL  
SINGLE LEG EXTENSION

DIMENSIONES | DIMENSIONS: 185.4 x 168.8 x 113.4 cm. | PESO | WEIGHT: 115 kg. | CARGA MAX. DISCOS | MAX LOAD PLATES: 300 kg.



**PL1027**  
SQUAT LUNGE UNILATERAL  
SQUAT LUNGE

DIMENSIONES | DIMENSIONS: 215 x 178 x 82 cm. | PESO | WEIGHT: 149 kg. | CARGA MAX. DISCOS | MAX LOAD PLATES: 200 kg.



**PL1021**  
JACA PÉNDULO  
PENDULUM SQUAT

DIMENSIONES | DIMENSIONS: 213 x 96 x 162.7 cm. | CARGA MAX. DISCOS | MAX LOAD PLATES: 300 kg.



**PL1022**  
SENTADILLA CON CINTURÓN  
DEEP BELT SQUAT

DIMENSIONES | DIMENSIONS: 171.2 x 175 x 143.2 cm. | PESO | WEIGHT: 114 kg. | CARGA MAX. DISCOS | MAX LOAD PLATES: 350 kg.



**PL1023**  
PATADA DE GLÚTEO  
GLUTE KICK BACK

DIMENSIONES | DIMENSIONS: 132.5 x 126 x 166.5 cm. | PESO | WEIGHT: 137 kg. | CARGA MAX. DISCOS | MAX LOAD PLATES: 100 kg.

# PRENSAS Y JACAS

## LEGS PRESS AND HACK SQUATS

### PTT0118

#### PRENSA INCLINADA 45° ELITE

45° INCLINED LEG PRESS ELITE

 DIMENSIONES | DIMENSIONS: 250 x 150 x 157 cm. |  PESO | WEIGHT: 306 kg.

 CARGA MAX. DISCOS | MAX LOAD PLATES: 400 kg.



### PTT0122

#### PRENSA INCLINADA 45° ELITE+

45° INCLINED LEG PRESS ELITE+

 DIMENSIONES | DIMENSIONS: 237.5 x 161.5 x 147 cm. |  PESO | WEIGHT: 249 kg.

 CARGA MAX. DISCOS | MAX LOAD PLATES: 400 kg.

### PC6074

#### PRENSA INCLINADA 45° PRO

45° INCLINED LEG PRESS PRO

 DIMENSIONES | DIMENSIONS: 205 x 100 x 147 cm. |  PESO | WEIGHT: 217 kg.

 CARGA MAX. DISCOS | MAX LOAD PLATES: 300 kg.







**PTT0120**  
**DUAL PRENSA INCLINADA 45°/JACA**  
 DUAL 45° INCLINED PRESS/HACK SQUAT



 **DIMENSIONES | DIMENSIONS:** 263.5 x 152 x 188 cm. | 
  **PESO | WEIGHT:** 210 kg. | 
  **CARGA MAX. DISCOS | MAX LOAD PLATES:** 500 kg.

**PTT0119**  
**JACA V-SQUAT DUAL ELITE**  
 DUAL HACK V-SQUAT ELITE

 **DIMENSIONES | DIMENSIONS:** 197.3 x 157 x 174.5 cm. | 
  **PESO | WEIGHT:** 130 kg. | 
  **CARGA MAX. DISCOS | MAX LOAD PLATES:** 400 kg.



**PTT0317**  
**JACA V-SQUAT PRO+**  
 HACK V-SQUAT PRO+

 **DIMENSIONES | DIMENSIONS:** 190 x 144.7 x 172.7 cm. | 
  **PESO | WEIGHT:** 245 kg. | 
  **CARGA MAX. DISCOS | MAX LOAD PLATES:** 350 kg.

# BANCOS BENCHES

BENCHES



**PTT0201F**  
BANCO PLANO  
FLAT BENCH

DIMENSIONES | DIMENSIONS: 157 x 64 x 40 cm. | PESO | WEIGHT: 25 kg.



**PTT0204F**  
BANCO REGULABLE  
ADJUSTABLE BENCH

DIMENSIONES | DIMENSIONS: 134.5 x 45 x 117 (Max.) / 41.5 (Min.) cm. | PESO | WEIGHT: 36 kg.



**10020**  
BANCO REGULABLE DECLINADO  
ADJUSTABLE DECLINE BENCH

DIMENSIONES | DIMENSIONS: 151 x 51 x 125 (Max.) / 57 (Min.) cm. | PESO | WEIGHT: 41 kg. | CARGA MÁXIMA | MAXIMUM LOAD: 500 kg.



**BA001**  
BANCO REGULABLE  
ADJUSTABLE BENCH

DIMENSIONES | DIMENSIONS: 130.2 x 64.4 x 45 cm. | PESO | WEIGHT: 44 kg. | CARGA MÁXIMA | MAXIMUM LOAD: 500 kg.



**PTT0228F**  
BANCO REGULABLE DECLINADO  
DECLINED ADJUSTABLE BENCH

DIMENSIONES | DIMENSIONS: 143 x 56 x 96 (Max.) / 62 (Min.) cm. | PESO | WEIGHT: 47 kg.



**PTT0205F**  
BANCO SILLA DE ENTRENAMIENTO  
TRAINING CHAIR BENCH

DIMENSIONES | DIMENSIONS: 120 x 77 x 106 cm. | PESO | WEIGHT: 22 kg.



## PTT0220F

### BANCO LUMBAR 45°

45° LUMBAR BENCH

 DIMENSIONES | DIMENSIONS: 142 x 82 x 83 cm. | 
  PESO | WEIGHT: 42 kg.



## PTT0224F

### BANCO LUMBAR DUAL RECLINABLE

LUMBAR DUAL RECLINABLE BENCH

 DIMENSIONES | DIMENSIONS: 160 x 94 x 108.5 cm. | 
  PESO | WEIGHT: 71 kg.



## PTT0218F

### BANCO ABDOMINAL 90°

90° AB BENCH

 DIMENSIONES | DIMENSIONS: 158 x 72 x 98 cm. | 
  PESO | WEIGHT: 51 kg.



## PTT0206F

### BANCO DE BÍCEPS

BICEPS BENCH



 DIMENSIONES | DIMENSIONS: 122 x 86 x 94 cm. | 
  PESO | WEIGHT: 50 kg.



## PL2580

### BANCO SENTADILLA SISSY

SISSY SQUAT BENCH



 DIMENSIONES | DIMENSIONS: 100 x 56 x 51 cm. | 
  PESO | WEIGHT: 42 kg. | 
  PESO MÁXIMO | MAXIMUM WEIGHT: 200 kg.



## PTT0229

### BANCO SISSY SENDATILLAS

SISSY SQUATS

 DIMENSIONES | DIMENSIONS: 125.2 x 75 x 38.8 cm. | 
  PESO | WEIGHT: 29.5 kg. | 
  PESO MÁXIMO | MAXIMUM WEIGHT: 150 kg.



**PTT0209F**  
BANCO PRESS HORIZONTAL  
HORIZONTAL PRESS BENCH

DIMENSIONES | DIMENSIONS: 175 x 172 x 136 cm. PESO | WEIGHT: 80 kg.

**PTT02090PC**  
RACK DE DISCOS  
PLATES RACK



**PTT0210F**  
PRESS INCLINADO  
INCLINED PRESS BENCH

DIMENSIONES | DIMENSIONS: 177 x 172 x 154 cm. PESO | WEIGHT: 115 kg.



**PTT02100PC**  
PLATAFORMA DE AYUDA  
SUPPORT PLATFORM

**PTT0211F**  
BANCO PRESS DECLINADO  
DECLINED PRESS BENCH

DIMENSIONES | DIMENSIONS: 207 x 172 x 136 cm. PESO | WEIGHT: 96 kg.



**PTT0208F**  
BANCO PRESS DE HOMBROS  
SHOULDER PRESS BENCH

DIMENSIONES | DIMENSIONS: 174 x 138 x 190 cm. PESO | WEIGHT: 114 kg.

**PTT02080PC**  
PLATAFORMA DE AYUDA  
SUPPORT PLATFORM

DIMENSIONES | DIMENSIONS: 56 x 39 x 37 cm.



**PTT0207F**  
RACK DE SENTADILLAS  
SQUAT RACK

DIMENSIONES | DIMENSIONS: 186 x 165 x 201 cm. PESO | WEIGHT: 145 kg.





**PTT0232F**  
GEMELO SENTADO  
SEATED CALF RISE

DIMENSIONES | DIMENSIONS: 139 x 62 x 94 cm. | PESO | WEIGHT: 54 kg.



**PTT0231F**  
REMO EN PUNTA  
T-BAR ROW

DIMENSIONES | DIMENSIONS: 181 x 113 x 120 cm. | PESO | WEIGHT: 62 kg.



**PTT0227F**  
BANCO DE ESTIRAMIENTO  
STRENGTH BENCH

DIMENSIONES | DIMENSIONS: 151 x 79 x 110 cm. | PESO | WEIGHT: 35 kg.



**PTT0235**  
BANCO REMO PRONO  
SEATED CALF RISE

DIMENSIONES | DIMENSIONS: 228 x 218 x 120 cm. | PESO | WEIGHT: 158 kg. | PESO MÁX. USUARIO | USER MAX WEIGHT: 150 kg.

- Incluye barra tipo cambered y dos collarines en metal cromado.
- Includes cambered bar and two chrome-plated metal collars.



**PTT0215F**  
FONDOS Y ABDOMINALES  
DIP/ABS STATION

DIMENSIONES | DIMENSIONS: 119 x 87 x 167 cm. | PESO | WEIGHT: 75 kg.



**PTT0219F**  
FONDOS / DOMINADAS Y ABDOMINALES  
PULL UP/DIP/ABS STATION

DIMENSIONES | DIMENSIONS: 119 x 126 x 230 cm. | PESO | WEIGHT: 93 kg.



**10018**  
**HIP THRUSTER ELITE**  
 HIP THRUSTER ELITE

DIMENSIONES | DIMENSIONS: 170 x 93 x 47 cm. | PESO | WEIGHT: 50 kg.

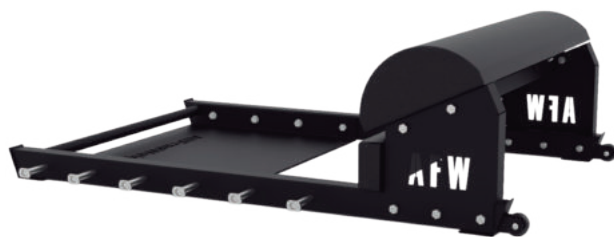

**BS001**  
**HIP THRUSTER KERSEY**  
 HIP THRUSTER KERSEY

DIMENSIONES | DIMENSIONS: 139 x 62 x 40 cm. | PESO | WEIGHT: 51 kg. | PESO MÁX. | MAX WEIGHT: 500 kg.



**558906**  
**HIP THRUSTER FOAM**  
 HIP THRUSTER FOAM

DIMENSIONES | DIMENSIONS: 91 x 50 x 35 cm. | PESO | WEIGHT: 4 kg.



**10019**  
**BANCO GHD ELITE**  
 GHD ELITE BENCH

DIMENSIONES | DIMENSIONS: 197 [MAX] / 162,5 [MIN] x 70 x 137 [MAX] / 127 [MIN] cm. | PESO | WEIGHT: 79 kg.





# PAVIMENTOS FLOORS



# CONTINENTAL FLOOR

## LOSETA DISPONIBLE CON Y SIN CRUCETA

FLOOR TILE AVAILABLE WITH AND WITHOUT CROSSPIECE

REF. B



## COLORES COLORS

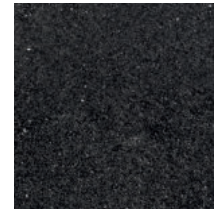

**Negro**  
Black  
REF. B

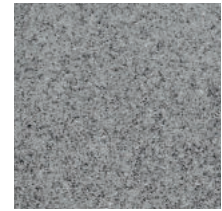

**Gris**  
Grey  
REF. G



REF. FR2002GN



REF. FR2001GN

## LOSETA NEGRA CON PARTÍCULAS EPDM DE COLORES BLACK TILE WITH COLOURED EPDM POLYURETHANE PARTICLES FLOORING

## PARTÍCULAS EPDM DE COLORES EPDM POLYURETHANE COLOURED PARTICLES



**Negro-rojo 200**  
Black-red  
REF. BR

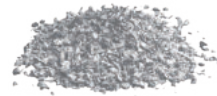

**Negro-blanco 105**  
Black-white  
REF. BW



**Negro-gris 101**  
Black-grey  
REF. BG

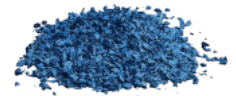

**Negro-azul 665**  
Black-blue  
REF. BB



**Negro-verde 517**  
Black-green  
REF. BV

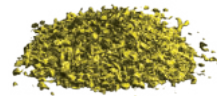

**Negro-Amarillo 329**  
Black-yellow  
REF. BY

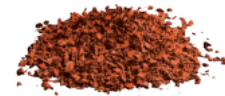

**Negro-naranja 218**  
Black-orange  
REF. BO

LOSETA / TILE	REF.	PESO / WEIGHT
10 mm.	FR1001	9.50 kg
15 mm.	FR1501	13.50 kg
15 mm. (gris-negro/grey-black)	FR1501GN	13.50 kg.
20 mm.	FR2001	17.00 kg
20 mm. (gris-negro/grey-black)	FR2001GN	17.00 kg.
20 mm. 50 x 50 cm. (pack 4)	FR2003	17.00 kg.
25 mm.	FR2501	19.44 kg
30 mm.	FR3001	23.80 kg
40 mm.	FR4001	31.10 kg
15 mm. (con cruceta/with crosspiece)	FR1502	13.50 kg
15 mm. (con cruceta gris-negro/with grey-black crosspiece)	FR1502GN	13.50 kg
20 mm. (con cruceta/with crosspiece)	FR2002	17.00 kg
20 mm. (con cruceta gris-negro/with grey-black crosspiece)	FR2002GN	17.00 kg
25 mm. (con cruceta/with crosspiece)	FR2502	19.44 kg
30 mm. (con cruceta/with crosspiece)	FR3002	23.80 kg
40 mm. (con cruceta/with crosspiece)	FR4002	31.10 kg
20 mm. (Negro-Blanco/Black-White)	FR2001BW	17 kg.
20 mm. (Negro-Rojo/Black-Red)	FR2001BR	17 kg.

## LOSETA 40 MM (INDOOR/OUTDOOR) TILE 40 MM (INDOOR/OUTDOOR)

REF. BX



Detalle parte inferior  
Detail below the  
surface floor

LOSETA / TILE	REF.	PESO / WEIGHT
40 mm. Pirámide-Pyramid	FR4051	26.40 kg
40 mm. Pirámide-Pyramid (gris-negro/grey-black)	FR4051GN	26.40 kg.
40 mm. Pirámide-Pyramid (con cruceta/with crosspiece)	FR4052	26.40 kg
Rampa-Ramp 40 mm. 50 x 50 cm.	FR4001R	6.15 kg
Esquina rampa-Corner ramp 40 mm. 50 x 50 cm.	FR4001E	6.00 kg

**RAMPA 40 MM.**RAMP  
REF. FR4001R

50 x 50 cm.

**ESQUINA RAMPA 40 MM.**CORNER RAMP  
REF. FR4001E

50 x 50 cm.

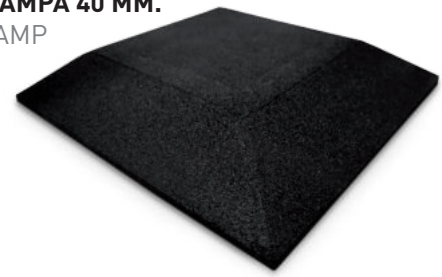

**Pavimento con mezcla de gránulos de SBR (0.5-2 mm) con resina de poliuretano incolora o coloreada.**  
Flooring with a mixture of SBR granules (0.5-2 mm) with colourless or coloured polyurethane resin.

- ▶ Antideslizante
- ▶ Resistente y durable
- ▶ Resistencia elástica
- ▶ Resistencia a la abrasión
- ▶ Aislamiento acústico.
- ▶ Anti-slip
- ▶ Resistant and durable
- ▶ Elastic resistance
- ▶ Abrasion resistance
- ▶ Acoustic insulation.

**CARACTERÍSTICAS TÉCNICAS**

## TECHNICAL CHARACTERISTICS

- Dimensiones / Dimensions: 100 x 100 cm. (loseta) - 39.38 x 39.38 in. (Tile).
- Tolerancia / Tolerance: Largo y ancho / Length and width  $\pm 1,5\%$  | Grosor / Thickness  $\pm 5\%$ .
- Disponible lisa o con cruceta desde 15 mm en adelante. / Available smooth or with cross brace from 15 mm upwards.

Las losetas pueden tener una variación en sus medidas de un 1% en el ancho y 2 mm. en el grosor debido a la flexibilidad del propio material.  
Tiles may vary in size by 1% in width and 2 mm. in thickness due to the flexibility of the material itself.

**MATERIAL**

## MATERIAL

- Composición / Composition: Loseta de caucho SBR procedente de reciclado de neumáticos y resina aromática. / SBR rubber tile made from recycled tyres and aromatic resin.
- Densidad / Density: 900 kg/m<sup>3</sup>. / 1984,16 lb/m<sup>3</sup>.
- Clasificación según reacción al fuego / Reaction to fire classification: E fl EN 13501.
- Resistencia al deslizamiento / Slip resistance: 36 (Clase 2) / (Class 2) EN 12633.
- Reducción de fuerzas en seco / Dry force reduction: 40% EN 14808.
- Deformación vertical / Vertical deformation surface: 1,6 mm. / 0,0629 in. EN 14809.
- Bote vertical en seco / Dry vertical can: 99% EN 12235.
- Resistencia a la abrasión / Abrasion resistance: 56,2 mg. EN ISO 5470.
- Resistencia a impacto / Impact resistance: <0,5 EN 1517.

**CERTIFICADOS DE CALIDAD**

## QUALITY CERTIFICATES

- Seguridad en equipamiento de superficies / Safety of surface equipment EN 1176-1:2017.
- Absorción de impactos / Shock absorption EN 1177:2018.

ENSAYO / TEST	VALOR / VALUE	CRITERIO / CRITERIA	RESULTADO / RESULT
Reducción de fuerzas en seco (%) / Dry force reduction (%) Uniformidad / Uniformity	40 3	25%-75% $\pm 5$	APTO / FIT
Deformación vertical estándar en seco (mm) / Standard dry vertical deflection (mm)	1,6	$\leq 5,0$ mm.	APTO / FIT
Bote vertical en seco (%) / Vertical dry can (%) Uniformidad / Uniformity	99 3	$\geq 90\%$ $\pm 3$	APTO / FIT
Resistencia al deslizamiento en seco / Resistance to dry sliding Uniformidad / Uniformity	104 1	$80 \leq \mu \leq 110$ $\pm 4$	APTO / FIT
* Resistencia al impacto (mm) / Impact resistance (mm)	< 0,5	$\leq 0,5$ mm Sin grietas ni deslaminación / No cracks or delamination	APTO / FIT
* Resistencia a la abrasión (mg) / Abrasion resistance (mg)	56,2	$\leq 1000$ mg	APTO / FIT

**Datos obtenidos para su uso interior**

Incertidumbre expandida (ensayo de reducción de fuerza): 2% (K=2,37).  
Incertidumbre expandida (ensayo de deformación): 0,2 mm (K=2,52).  
Incertidumbre expandida (ensayo de bote vertical): 2% (K=2,65).  
Incertidumbre expandida (ensayo de resistencia al deslizamiento): 3 (K=2,00).  
Fr (hormigón): 6402N (10/09/2021)

**Data obtained for indoor use**

Expanded uncertainty (strength reduction test): 2% (K=2.37).  
Expanded uncertainty (deformation test): 0,2 mm (K=2,52).  
Expanded uncertainty (vertical bounce test): 2% (K=2,65).  
Expanded uncertainty (slip resistance test): 3 (K=2,00).  
Fr (concrete): 6402N (10/09/2021).

**PESO Y UNIDADES POR PALET**

## WEIGHT AND UNITS PER PALLET

GROSOR LOSETA / TILE THICKNESS	PESO LOSETA / TILE WEIGHT	UNIDADES POR PALET / UNITS PER PALLET
10 mm.	9.50 kg	80
15 mm.	13.50 kg	75
20 mm.	17.00 kg	60
25 mm.	19.44 kg	50
30 mm.	23.80 kg	40
40 mm. maciza / solid	31.10 kg	33
40 mm. piramidal / pyramidal	26.40 kg	33
40 mm. rampa / ramp 50 x 50 cm.	6.15 kg	90
40 mm. esquina / corner 50 x 50 cm.	6.00 kg	90

\* Loseta disponible con y sin cruceta. Consultar stock.  
\* Pavimento color negro. También disponible en gris.

\* Floor Tile available with and without crosspiece. Consult stock.  
\* Black flooring. Also available in grey.

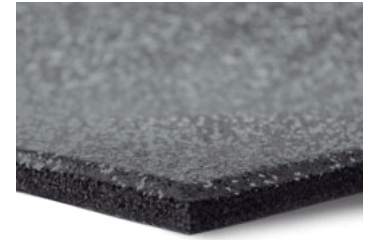

Detalle  
Detail

## FRF20NB

### TOP FLOOR FLECKS

- Composición: Caucho SBR reciclado, adhesivo de poliuretano MDI, pigmentos de color y partículas de EPDM 100%.
- Superficie antideslizante, porosa, lisa, con alta absorción de impacto, de fácil limpieza y mantenimiento y especialmente resistente a la abrasión.
- Está indicado para salas de fitness, zonas de peso libre y crosstraining. Producto para interior.
- Composition: Recycled SBR rubber, MDI polyurethane adhesive, colour pigments and 100% EPDM particles.
- Non-slip, porous, smooth surface with high impact absorption, easy to clean and maintain and particularly resistant to abrasion.
- It is suitable for fitness rooms, free weight areas and cross-training. Indoor product.

#### Certificados de calidad

- Resistencia al fuego: Efl (B2) a,c (EN 13501).
- Reacción al fuego: Fs <150 mm en 20 segundos (ISO 11925).
- Aislamiento acústico al impacto: 26 dB (ISO 10140).
- Aislamiento acústico: 48 dB (ISO 10140).

#### Quality certificates

- Fire resistance: Efl (B2) a,c (EN 13501).
- Reaction to fire: Fs <150 mm in 20 seconds (ISO 11925).
- Impact sound insulation: 26 dB (ISO 10140).
- Sound insulation: 48 dB (ISO 10140).

 **DIMENSIONES | DIMENSIONS:**  
1 x 1 m. x 20 mm.

 **PESO | WEIGHT:**  
18 kg.

- Color: Negro/gris.
- Densidad: 950-980 kg/m<sup>3</sup>.
- Dureza: 60 ± 3 Shore A.
- Colour: Black/grey.
- Density: 950-980 kg/m<sup>3</sup>.
- Hardness: 60 ± 3 Shore A.

Detalle  
Detail

## FG2020

### TOP FLOOR CON CÉSPED

#### TOP FLOOR WITH TURF

- Top Floor con césped es la combinación inmejorable de unir el resultado estético que proporciona el césped artificial con la suave amortiguación de una baldosa de caucho.
- Composición: Caucho SBR reciclado, adhesivo de poliuretano MDI, pigmentos de color, 9.000 / 6 DTEX Monofilamento (± 5%) 100% Polietileno 300 (PE) Micrón (± 5%) Verde hierba.
- Producto para interior y exterior.
- Top Floor with grass is the unbeatable combination of combining the aesthetic result of artificial grass with the soft cushioning of a rubber tile.
- Composition: Recycled SBR rubber, MDI polyurethane adhesive, colour pigments, 9.000 / 6 DTEX Monofilament (± 5%) 100% Polyethylene 300 (PE) Micron (± 5%) Grass green.
- Indoor and outdoor product.

 **DIMENSIONES | DIMENSIONS:**  
98 x 98 cm.

- Grosor: 20 mm (loseta) + 20 mm. (césped).
- Peso loseta: 24 kg.
- Densidad: 750-780 kgs/m<sup>3</sup>.
- Dureza: 55 ± 3 Shore A.
- Thickness: 20 mm (tile) + 20 mm (turf).
- Tile weight: 24 kg.
- Density: 750-780 kgs/m<sup>3</sup>.
- Hardness: 55 ± 3 Shore A.

## 105410/410G

### TATAMI

- Adecuado para actividades que conllevan caídas continuas o intensas; recuperando gradualmente la forma. También se puede utilizar en salas de estudio donde se imparte Yoga, Pilates...
- Fabricado en Goma Eva con terminación en los 4 lados lisos. Tipo puzzle extraíbles. Reversible en color Azul/Rojo y Negro/Gris.
- De instalación rápida y fácil.
- Suitable for activities that involve continuous or intense falls; gradually regaining shape. It can also be used in study rooms where Yoga, Pilates... are taught.
- Made of Eva rubber with 4 smooth sides. Removable puzzle type. Reversible in Blue/Red and Black/Grey.
- Quick and easy to install.

 **DIMENSIONES | DIMENSIONS:**  
100 x 100 cm. x 26 mm. (grosor / thickness) / 107 x 107 cm. (con cierre de ensamble / with assembly lock)

 **PESO | WEIGHT:**  
3 kg.

COLOR / COLOR	REF.
Azul/Rojo - Blue/Red	105410
Negro/Gris - Black/Grey	105410G

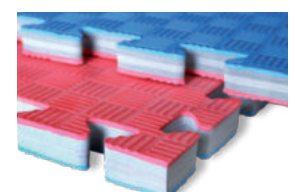
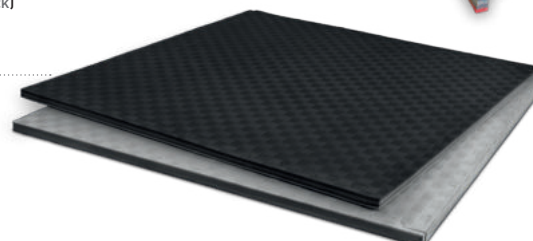
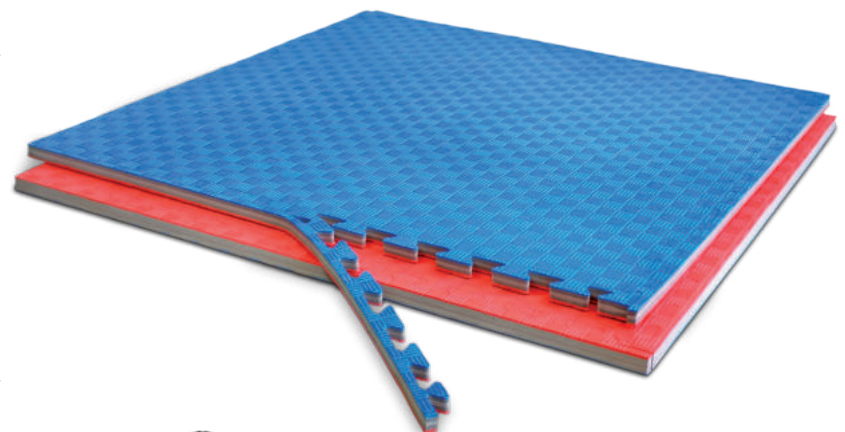
Detalle del ensamble  
Assembly detail



## PAV1182 CÉSPED MODEL NIZA PRO

- Césped artificial a 4 colores de 30 mm. (+/-1). Muy agradable al tacto, gran suavidad, estabilizador anti-UV y con un mínimo mantenimiento.
- Artificial turf in 4 colours of 30 mm (+/-1). Very pleasant to the touch, very soft, anti-UV stabiliser and low maintenance.

**DIMENSIONES | DIMENSIONS:**  
10 x 2 m x 30 mm.

**PESO | WEIGHT:**  
3 kg.

- Dtex: PE (4.400) + PP (3.300) (+/- 3%).
- Puntadas m2: 17.850 (+/- 3%).
- Base: PP + Paño no tejido + Látex.
- Drenaje: 1600 - 1800 l/h/m2.
- Clasificación reacción al fuego: DIN 51960 Class 2.
- Dtex: PE (4.400) + PP (3.300) (+/- 3%).
- Stitches m2: 17.850 (+/- 3%).
- Base: PP + Non-woven cloth + Latex.
- Drainage: 1600 - 1800 l/h/m2.
- Reaction to fire classification: DIN 51960 Class 2.

## PERFILES PROFILES

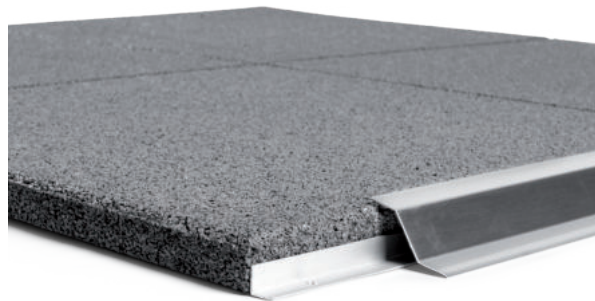

Perfil terminación rampa  
Ramp termination profile



Rampa aluminio plata  
Aluminium ramp silver



Perfil ángulo  
Profile angle

	REF.
Perfil terminación rampa 250 cm. adhesivo (suelo de 15 mm). Adhesive 250 cm ramp termination profile (15 mm floor).	105411
Perfil ángulo 15 x 15 aluminio 300 cm taladro interior. Angle profile 15 x 15 aluminium 300 cm inner bore.	105412
Perfil ángulo 20 x 8 aluminio adhesivo 300 cm. Angle profile 20 x 8 aluminium adhesive 300 cm.	105413
Perfil ángulo 20 x 8 aluminio 200 cm negro taladro superior. Angle profile 20 x 8 aluminium 200 cm black top hole.	105413-200
Rampa 5 mm aluminio plata taladros (lámina 300 cm). Ramp 5 mm aluminium silver drilled holes (sheet 300 cm).	PD504PT
Rodapie 70 mm anodizado plata mate 300 cm. Skirting 70 mm matt silver anodised 300 cm.	105414
Perfil terminación rampa 200 cm adhesivo (suelo de 20 mm). Ramp end profile 200 cm adhesive (20 mm floor).	105416
Rampa aluminio plata taladros (lámina 300 cm). Silver aluminium ramp with drilled holes (sheet 300 cm).	PD804PT
Perfil ángulo 28 x 28 aluminio plata adhesivo. Profile angle 28 x 28 aluminium silver adhesive.	PD566PA
Perfil terminación rampa 200 cm adhesivo (suelo de 30 mm). Ramp end profile 200 cm adhesive (30 mm floor).	105418



## FG003 CÉSPED ESCALERA FUNCIONAL FUNCTIONAL TURF ARTIFICIAL GRASS

- Carril de césped con marcas para medición durante la actividad. Sin efectos ambientales nocivos.
- Uso duradero.
- Fácil de mantener. Se aconseja fijarlo.
- Grass track with markings for measurement during activity. No harmful environmental effects.
- Durable in use.
- Easy to maintain. Fixing is recommended.

**DIMENSIONES | DIMENSIONS:**  
10.5 x 2 m.

**PESO | WEIGHT:**  
125 kg.

## 105420 FIJADOR/COLA MIPLAFIX 800 MIPLAFIX 800 GLUE/FIXER



- Alta resistencia a la cizalla.
- Total bloqueo del revestimiento.
- Apto para suelos radiantes.
- Sin disolventes ni ftalatos.
- Presentación: Marfil en bote de 18 kg.
- High shear strength.
- Total locking of the coating.
- Suitable for underfloor heating.
- Solvent and phthalate free.
- Pack size: Ivory in 18 kg tin.

## 105449 FIJADOR/COLA DECOGREEN DECOGREEN GLUE/FIXER



- Adhesivo base poliuretano de dos componentes, color verde (RAL 6025), para el encolado de césped artificial.
- Altas prestaciones adhesivas.
- Resistente a la humedad. Uso interior / exterior.
- Resistente a altas temperaturas, hasta +120° C.
- De fácil aplicación.
- No contiene agua ni disolventes.
- Two-component polyurethane based adhesive, green (RAL 6025), for gluing artificial turf.
- High adhesive performance.
- Moisture resistant. Indoor / outdoor use.
- Resistant to high temperatures up to +120°C.
- Easy to apply.
- Does not contain water or solvents.

## 105440 BOSTIK ROLL 85 MM. X 50 M.



- Instalación duradera y permanente. Ultra resistente.
- Instalación fácil y limpia. Agarre inmediato.
- Resistente a la migración de plastificantes.
- Alta resistencia a la temperatura (-40° C a +120° C).
- Compatible con suelos radiantes.
- Durable and permanent installation. Ultra resistant.
- Easy and clean installation. Immediate adhesion.
- Resistant to plasticiser migration.
- High temperature resistance (-40° C to +120° C).
- Compatible with underfloor heating.

- Regulación de la presión de los cepillos: la regulación de la presión de los cepillos asegura una mejor calidad de limpieza.
- Función de prelavado: la fregadora ofrece la posibilidad de desactivar la recuperación de la solución detergente para efectuar el prelavado, función útil donde se presenta un nivel elevado de suciedad.
- Limpieza total de los suelos incluso en las zonas más difíciles: elimina la suciedad de debajo de los muebles, a lo largo de los rodapiés y en las esquinas.
- Bidireccionalidad: su originalidad de diseño y su máxima manejabilidad permiten a la fregadora cambiar el sentido de marcha invirtiendo la posición del mango. Esta operación de "volteo" facilita las operaciones de limpieza - derecha/izquierda adelante/atrás y viceversa - especialmente en espacios reducidos.

- Brush pressure regulation: Brush pressure regulation ensures better cleaning quality.
- Prewash function: the scrubber offers the possibility of deactivating the recovery of the detergent solution to carry out the prewash, a useful function where there is a high level of dirt.
- Complete floor cleaning even in the most difficult areas: removes dirt from under furniture, along baseboards and in corners.
- Bidirectionality: its original design and maximum maneuverability allow the scrubber to change the direction of travel by reversing the position of the handle. This "flip" operation facilitates cleaning operations - right/left forward/backward and vice versa - especially in tight spaces.

## 558910

### FREGADORA PAVIMENTOS DE CAUCHO

RUBBER FLOORING SCRUBBER

- Superficie de trabajo: 300 / 500 M<sup>2</sup>/h.
- Anchura de lavado: 350 mm.
- Dimensiones: 420 x 430 x 250 mm.
- Peso en vacío: 30 kg.
- Número cepillos: 2.
- Alimentación: Cable.
- Tensión: 115-240 Volt.
- Frecuencia: 60-50 Hz.
- Nivel de ruido: < 64dBA.
- Tanque de la solución: 2.7 Lt.
- Tanque de recuperación: 2.3 Lt.
- Velocidad cepillos: 650/750 rpm.
- Presión de los cepillos: 200 gr/cm<sup>2</sup>
- Peso en vacío: 30 kg.
- Potencia absorbida: 1000 + 900 Watt.
- Ancho del chorro de vapor: 330 mm.
- Dimensiones embalaje: 650 x 510 x 360 mm.

- Working area: 300 / 500 M<sup>2</sup>/h.
- Washing width: 350 mm.
- Dimensions: 420 x 430 x 250 mm.
- Empty weight: 30 kg.
- Number of brushes: 2.
- Power supply: Cable.
- Voltage: 115-240 Volt.
- Frequency: 60-50 Hz.
- Noise level: < 64dBA.
- Solution tank: 2.7 Lt.
- Recovery tank: 2.3 Lt.
- Brush speed: 650/750 rpm.
- Brush pressure: 200 gr/cm<sup>2</sup>.
- Empty weight: 30 kg.
- Power absorbed: 1000 + 900 Watt.
- Steam jet width: 330 mm.
- Packing dimensions: 650 x 510 x 360 mm.







# ACCESSORIOS

ACCESSORIES





**105450**  
**AGARRE DE POLEA ALTA 120 CM.**  
 LAT PULLDOWN BAR 120 CM.



**105451**  
**AGARRE PARALELO DORSAL**  
 PARALLEL GRIP LAT PULLDOWN BAR



**105452**  
**AGARRE ESPECIAL BÍCEPS/TRÍCEPS**  
 SPECIAL BICEPS/TRICEPS HANDLE



**105458**  
**AGARRE BÍCEPS/TRÍCEPS**  
 BICEPS/TRICEPS HANDLE



**105459**  
**AGARRE TRÍCEPS RECTO**  
 STRAIGHT TRICEP HANDLE



**105454**  
**AGARRE TRÍCEPS CURVO**  
 CURVED TRICEPS HANDLE



**105461**  
**AGARRE REMO ANCHO**  
 WIDE GRIP MULTI PURPOSE ROWING



**105457**  
**AGARRE REMO EN V**  
 V HANDLE



**105456**  
**AGARRE ESTRIBO**  
 STIRRUP GRIP

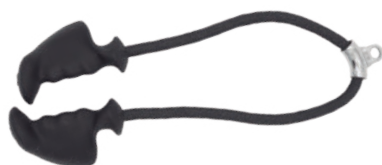

**552103**  
**AGARRE DE POLEA CUERDA ERGONÓMICO**  
 ERGONOMIC ROPE PULLEY GRIP



**13100**  
**AGARRE DE POLEA ABDOMINAL**  
 ABDOMINAL PULLEY GRIP



**105455**  
**AGARRE POLEA CUERDA**  
 TRICEPS ROPE HANDLE



**105460**  
**AGARRE CUERDA A UNA MANO**  
 ONE HAND ROPE GRIP



**105463**  
**AGARRE ESTRIBO NYLON**  
 NYLON STIRRUP GRIP



**552104**  
**AGARRE DE POLEA ESTRIBO NYLON ERGONÓMICO (PAR)**  
 ERGONOMIC NYLON STIRRUP PULLEY GRIP (PAIR)



**105462**  
**AGARRE TOBILLERO CON VELCRO**  
 ANKLE STRAP



**552106**  
**AGARRE POLEA TOBILLO-GLÚTEO (PAR)**  
 ANKLE/GLUTEUS PULLEY GRIP (PAIR)



**552102**  
**AGARRE DE TOBILLO EN CUERO NATURAL**  
 ANKLE GRIP IN NATURAL LEATHER



## 552101 SET 5 AGARRES DE POLEA

SET 5 PULLEY GRIPS

- Fabricado con material muy resistente revestido en caucho rugoso antideslizante, con agarres ergonómicos redondeados y seguros, que brindan estabilidad y control en los levantamientos.
- Tipos de agarres que incluye: Agarre ancho, Agarre medio supinación, Agarre medio pronación, Agarre cerrado supinación y Agarre cerrado neutro.
- Made of very resistant material covered in rough non-slip rubber, with rounded and secure ergonomic grips, which provide stability and control when lifting.
- Types of grips including: Wide grip, Medium supination grip, Medium pronation grip, Supination close grip and Neutral closed grip.

**DIMENSIONES | DIMENSIONS:**  
 Grosor agarres / Grip thickness: 3 cm.  
 Agarre ancho / Wide grip  
 74 x 13 x 14 cm.  
 Agarre medio supinación / Medium supination grip  
 52 x 14 x 17 cm.  
 Agarre medio pronación / Medium pronation grip  
 52 x 13 x 17 cm.  
 Agarre cerrado supinación / Closed supination grip  
 30 x 12.5 x 15 cm.  
 Agarre cerrado neutro / Neutral closed grip  
 25 x 12.5 x 16 cm.

## 552105 SET 8 AGARRES DE POLEA

SET 8 PULLEY GRIPS

- Fabricado en acero Q235, con agarres ergonómicos en goma redondeados y seguros, que brindan libertad y control en los levantamientos.
- Tipos de agarres que incluye: Agarre ancho ajustable, agarre medio ajustable, agarre barra multifunciones, agarres individuales pájaro, agarre cerrado móvil, agarre medio móvil, agarre ancho móvil, agarre multidireccional extensión larga.
- Made of Q235 steel, with ergonomic, rounded and secure rubber grips, providing freedom and control when lifting.
- Types of grips including: Adjustable wide grip, adjustable medium grip, multifunction bar grip, individual bird grips, mobile closed grip, mobile medium grip, mobile wide grip, long extension multidirectional grip.

**DIMENSIONES | DIMENSIONS:**  
 Dimensiones agarre / Grip dimensions:  
 20.5 x 22 x 3 cm.  
 Agarre ancho ajustable / Adjustable wide grip:  
 7 x 96.56 cm.  
 Agarre medio ajustable / Adjustable medium grip:  
 7 x 50 cm.  
 Agarre barra multifunciones / Multifunction bar grip:  
 14 x 44 cm.  
 Agarres individuales pájaro / Individual bird grips:  
 22 x 20.5 cm.  
 Agarre cerrado móvil / Movable closed grip:  
 16 x 32 cm.  
 Agarre medio móvil / Movable medium grip:  
 16 x 50.5 cm.  
 Agarre ancho móvil / Mobile wide grip:  
 16 x 66 cm.  
 Agarre multidireccional extensión larga / Long extension multi-directional grip:  
 54 x 43 cm.



## 952001 RACK VERTICAL AGARRES POLEAS

VERTICAL SUPPORT PULLEY GRIPS

- Tiene una capacidad para 8 agarres en total: 5 agarres en la parte frontal y 3 en la parte posterior.
- No es compatible con los agarres individuales debido al diseño de la argolla de estos.
- Fabricado en hierro con terminación epoxi.
- No incluye set de agarres.
- It has a capacity for 8 grips in total: 5 grips in the front and 3 in the back.
- Not compatible with individual grips due to the ring design of this.
- Made of iron with epoxy finish.
- Grip set not included.

**DIMENSIONES | DIMENSIONS:** 30.5 x 57 x 92 cm. **PESO | WEIGHT:** 5.6 kg.



## 105036 RACK VERTICAL AGARRES POLEAS

VERTICAL SUPPORT PULLEY GRIPS





- Almacena hasta 15 accesorios. (Agarres)
- Pieza con gran estabilidad.
- Fabricado en hierro con exclusivo acabado de pintura "Tuff Coat" para mayor durabilidad, color negro.
- Store up to 15 accessories. (Grips)
- Piece with great stability.
- Made of iron with exclusive paint finish "Tuff Coat" for durability, black color.

**DIMENSIONES | DIMENSIONS:** Ø 50 x 110 cm.  
**PESO | WEIGHT:** 25 kg.

# 110080

## BARRA HARD CHROMED PREMIER 220 CM.

HARD CHROMED BAR PREMIER 220 CM.

-  20 KG.
-  28 MM.
-  1.2 MM. STANDARD
-  50 MM. MÁX. 500 LB.
-  KNURL



# 12524

## BARRA CHROMED PREMIER 183 CM.

PREMIER CHROMED BARBELL 183 CM.

-  13.3 KG.
-  28 MM.
-  REGULAR
-  50 MM.
-  KNURL

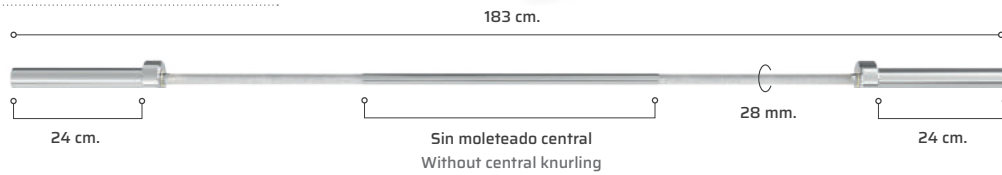

# 12522

## BARRA CHROMED PREMIER 150 CM.

PREMIER CHROMED CURL BAR 150 CM.

-  12 KG.
-  28 MM.
-  REGULAR
-  50 MM.
-  KNURL

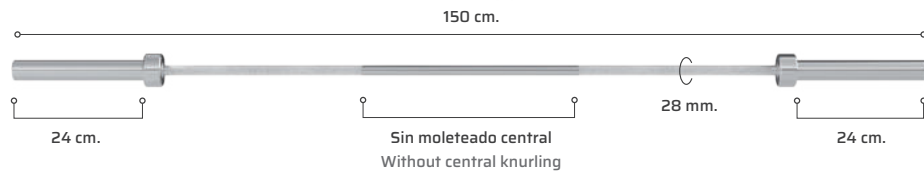

# 12523

## BARRA CHROMED PREMIER 120 CM.

PREMIER CHROMED CURL BAR 120 CM.

-  9 KG.
-  28 MM.
-  REGULAR
-  50 MM.
-  KNURL

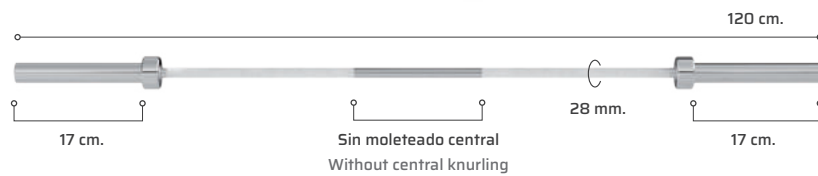

# 12525

## BARRA PREMIER CHROMED CURL Z 120 CM.

PREMIER CHROMED CURL Z BAR 120 CM.

-  9 KG.
-  28 MM.
-  REGULAR
-  50 MM.
-  KNURL





## 105114

### BARRA HEXAGONAL PROMAX

PROMAX HEX BARBELL

- Fabricada en acero con acabado cromado
- Made of steel with chrome finish.

 DIMENSIONES | DIMENSIONS:  
184 x 69 x 16 cm.

 PESO | WEIGHT:  
32 kg.

 ZONA DE CARGA | LOADING ZONA:  
33 cm.

 CARGA MÁXIMA | MAXIMUM LOAD:  
500 lb.





## 105106

### BARRA TRÍCEPS D. 50

TRICEPS BAR D. 50

- Barra para discos de diámetro 50 mm.
- Fabricada en acero.
- Agarre de Ø 28 mm.
- Bar for 50 mm. diameter discs.
- Made of Steel.
- Grip Ø 28 mm.

 DIMENSIONES | DIMENSIONS:  
85 x 20 cm.

 PESO | WEIGHT:  
11.5 kg.

 CARGA MÁXIMA | MAXIMUM LOAD:  
500 lb.



## 438507

### BARRA SENTADILLA PREMIUM

SQUAT BAR PREMIUM

- Barra de 220 cm para discos de diámetro 50 mm.
- Incluye protectores para hacer de las sentadillas un ejercicio más cómodo y controlado. Máxima estabilidad.
- Fabricada en acero inoxidable A3 de alta calidad.
- Almohadilla acolchada con FDAM de alta calidad.
- Acabado hard-chrome y tratamiento cerámico negro.
- 220 cm bar for 50 mm diameter discs.
- Includes protectors to make squats a more comfortable and controlled exercise. Maximum stability.
- Made of high quality A3 stainless steel.
- High quality FDAM cushioned padding.
- Hard-chrome finish and black ceramic treatment.

 AGARRE | GRIP:  
30 mm.

 ZONA DE CARGA | LOADING ZONA:  
31 cm.

 PESO | WEIGHT:  
24 kg.

 CARGA MÁXIMA | MAXIMUM LOAD:  
318 kg.





## 556101

### PROTECTOR CERVICAL

CERVICAL PROTECTOR

- Fabricado en goma EVA resistente.
- Lavable.
- Made of resistant EVA rubber.
- Washable.

 DIMENSIONES | DIMENSIONS:  
36 x 7 x 7 cm.

 PESO | WEIGHT:  
0.28 kg.

## 105110

### COLLARÍN BARRA AFW D. 50

AFW BAR COLLAR D. 50

- Material: metal cromado.
- Chromed metal clamp.

 DIMENSIONES | DIMENSIONS:  
Ø 50 mm.



## 938101

### RACK 9 BARRAS ROOT VERTICAL

9 BARS ROOT HOLDER

- Soporte fabricado en hierro con terminación epoxi negro, para 9 barras de diámetro 50 mm. y de colocación vertical.
- Support made of iron with black epoxy finish, for 9 bars of 50 mm diameter and vertical placement.

 DIMENSIONES | DIMENSIONS:  
44 x 44.5 x 17 cm.



## 554201/01

### COLLARÍN BARRA D50 ROCK

D50 ROCK BAR COLLAR

- Collarín fabricado en nylon de gran resistencia.
- Collar made of highly resistant nylon.

 DIMENSIONES | DIMENSIONS:  
8.5 x 4.5 x 8.5 cm / Ø 5.5 mm.



## 442204

### MANCUERNAS DE GOMA R PLUS

RUBBER DUMBBELLS PLUS R

- Mancuernas de goma (caucho 100% de alta calidad) con agarres de acero cromado con forma recta, antideslizantes para mayor adherencia.
- Rubber dumbbells (100% high quality rubber) with chromed steel grip, anti-slip for greater grip.

**DIMENSIONES | DIMENSIONS:**  
 Agarre / Grip: Ø 32 mm. x 15 cm. (largo/length).

**PESO | WEIGHT:**  
 2.5 - 50 kg., en incremento de/in increments of 2.5 kg.



## 438804-100

### KIT 5 BARRAS RECTAS BÍCEPS GOMA R PLUS 10 A 30 KG

KIT 5 STRAIGHT BICEPS BARS 10KG TO 30KG RUBBER R PLUS

- Barras de acero con cabezas revestidas de caucho lo que aumenta la durabilidad, protegen el suelo y el equipamiento, mejoran la apariencia, disminuyen el ruido y son fáciles de limpiar.
- Peso revestido de goma con alto relieve y codificación numérica en rojo.
- Juego compuesto de 5 barras rectas.

**DIMENSIONES | DIMENSIONS:**  
 Zona de agarre / Grip area: 95 cm. Diámetro agarre / Grip diameter: 33 mm.

**REF. 438804-100**  
**PESO | WEIGHT:**  
 10 - 30 kg.

**REF. 438804-225**  
**PESO | WEIGHT:**  
 35 - 55 kg.

## 438804-225

### KIT 5 BARRAS RECTAS BÍCEPS GOMA R PLUS 35 A 55 KG

KIT 5 STRAIGHT BICEPS BARS 10KG TO 30KG RUBBER R PLUS

- Steel bars with rubber coated heads increase durability, protect floors and equipment, improve appearance, reduce noise and are easy to clean.
- Rubberized weight with high relief and red numerical coding.
- Set consisting of 5 straight bars.



## 438805-100

### KIT 5 BARRAS Z BÍCEPS GOMA R PLUS 10 A 30 KG

KIT 5 Z BICEPS BARS 10 TO 30 KG GOMA R PLUS

- Barras de acero con cabezas revestidas de caucho lo que aumenta la durabilidad, protegen el suelo y el equipamiento, mejoran la apariencia, disminuyen el ruido y son fáciles de limpiar.
- Peso revestido de goma con alto relieve y codificación numérica en rojo.
- Juego compuesto de 5 barras Z.

**DIMENSIONES | DIMENSIONS:**  
 Zona de agarre / Grip area: 95 cm. Diámetro agarre / Grip diameter: 33 mm.

## 438805-225

### KIT 5 BARRAS Z BÍCEPS GOMA R PLUS 35 A 55 KG

KIT 5 Z BICEPS BARS 35 TO 55 KG GOMA R PLUS

- Steel bars with rubber coated heads increase durability, protect floors and equipment, improve appearance, reduce noise and are easy to clean.
- Rubberized weight with high relief and red numerical coding.
- Set consisting of 5 Z bars.

**REF. 438805-100**  
**PESO | WEIGHT:**  
 10 - 30 kg.

**REF. 438805-225**  
**PESO | WEIGHT:**  
 35 - 55 kg.



## 442203

### MANCUERNAS REDONDAS ACERO IRON

ROUNDS STEEL DUMBBELLS IRON

- Mancuerna profesional de núcleo de acero de alta calidad.
- Chapa con corte de láser.
- Agarre moleteado en negro ionizado de 35 mm.
- High quality professional steel core dumbbell.
- Laser-cut plate.
- Ionized black 35 mm knurled grip.

 DIMENSIONES | DIMENSIONS:  
Agarre / Grip: Ø 35 mm.

 PESO | WEIGHT:  
442203-39: Juego de mancuernas/dumbbell set 2.5 a 30 kg, en  
incremento de/ in increase of 2.5 kg  
Pesos disponibles de/Weights available from 35 hasta/to 100 kg.



## 438802-100

### KIT 5 BARRAS RECTAS BÍCEPS IRON 10 A 30 KG

KIT 5 STRAIGHT BICEPS BARS 10 TO 30 KG IRON

- Barras de acero profesional con cabeza en acero de alta calidad.
- Chapa con corte de láser.
- Agarre moleteado.
- Juego compuesto de 5 barras rectas.

 DIMENSIONES | DIMENSIONS:  
Zona de agarre / Grip area: 94.5 cm. Diámetro agarre / Grip diameter: 31 mm.

## 438802-225

### KIT 5 BARRAS RECTAS BÍCEPS IRON 35 A 55 KG

KIT 5 STRAIGHT BICEPS BARS 10 TO 30 KG IRON

- Professional steel bars with high quality steel head.
- Laser cut sheet metal.
- Knurled grip.
- Set of 5 straight bars.

 REF. 438802-100  
PESO | WEIGHT:  
10 - 30 kg.

 REF. 438802-225  
PESO | WEIGHT:  
35 - 55 kg.



## 438803-100

### KIT 5 BARRAS Z BÍCEPS 10 A 30 KG IRON

KIT 5 BICEPS Z-BARS 10 TO 35 KG

- Barras de acero profesional con cabeza en acero de alta calidad.
- Chapa con corte de láser.
- Agarre moleteado.
- Juego compuesto de 5 barras Z.

 DIMENSIONES | DIMENSIONS:  
Zona de agarre / Grip area: 94.5 cm. Diámetro agarre / Grip diameter: 31 mm.

## 438803-225

### KIT 5 BARRAS Z BÍCEPS 35 A 55 KG IRON

KIT 5 STRAIGHT BICEPS BARS 35 TO 55 KG IRON

- Professional steel bars with high quality steel head.
- Laser cut sheet metal.
- Knurled grip.
- Set of 5 Z bars.

 REF. 438803-100  
PESO | WEIGHT:  
10 - 30 kg.

 REF. 438803-225  
PESO | WEIGHT:  
35 - 55 kg.



## 442701 MANCUERNA PAIK PVC

PVC PAIK DUMBBELLS

- Mancuernas de PVC con agarres de acero cromado, antideslizantes para mayor adherencia.
- Gran calidad y durabilidad.
- PVC dumbbells with chrome-plated steel grips, non-slip for better grip.
- High quality and durable.

**DIMENSIONES | DIMENSIONS:**  
Agarre / Grip: Ø 33 mm. x 15 cm. (largo/length).

**PESO | WEIGHT:**  
2.5 - 50 kg., en incremento de/in increments of 2.5 kg.



## 942110

### RACK MANCUERNAS HEXAGONALES 3 BANDEJAS

HEXAGONAL DUMBBELL RACK 3 TRAYS

- Rack de mancuernas hexagonales de 2.5 a 30 kg. (12 pares) y 12.5 a 30 kg. (8 pares).
- Fabricado en acero de alta calidad.
- Acabado en pintura epoxi color negro mate en polvo.
- Bandeja de 148 x 30 x 0.2 cm.
- Rack of hexagonal dumbbells from 2.5 to 30 kg (12 pairs) and 12.5 to 30 kg (8 pairs).
- Made of high quality steel.
- Finished in matte black epoxy powder paint.
- Tray of 148 x 30 x 0.2 cm.

**DIMENSIONES | DIMENSIONS:** 156.5 x 86 x 110.7 cm. **PESO | WEIGHT:** 80.2 kg.



## 19249

### RACK 5 BARRAS HORIZONTAL

PVC PAIK DUMBBELLS

- Estructura metálica con apoyos cromados.
- Gomas en los apoyos para evitar rayaduras.
- Bases de goma.
- Fabricado en hierro con terminación en epoxi color negro.
- Posibilidad de unir dos soportes y obtener el doble de almacenaje.
- Metal structure with chromed supports.
- Rubber on the supports to avoid scratches.
- Rubber bases.
- Made of steel with a black epoxy finish.
- Possibility of joining two racks and obtain double storage.

**DIMENSIONES | DIMENSIONS:** 90 x 50 x 120 cm. **PESO | WEIGHT:** 17 kg.

## 942102

### RACK MANCUERNAS 2 BALDAS 10 PARES

2-TIER 10 PAIRS DUMBBELLS STORAGE

- Estructura fabricada en acero 50 x 100 x 2 mm.
- Acabado en pintura epoxi color negro mate en polvo.
- Bases para mancuernas en baldas engomadas en PVC.
- Structure made of steel 50 x 100 x 2 mm.
- Finished in matte black epoxy powder paint.
- Dumbbell bases on PVC rubberized shelves.

**DIMENSIONES | DIMENSIONS:** 230 x 88 x 81 cm. **PESO | WEIGHT:** 54 kg.



## 105039

### RACK MANCUERNAS 2 BALDAS 6 PARES

2-TIER 6 PAIRS DUMBBELLS STORAGE

- Fabricado en hierro con terminación en epoxi color negro.
- Bases para mancuernas fabricadas en PVC.
- Bases engomadas.
- Balda de 141 x 21.5 cm.
- Made of iron with a black epoxy finish.
- Dumbbell bases made from PVC.
- Gummed bases.
- Tier 141 x 21.5 cm.

**DIMENSIONES | DIMENSIONS:** 141 x 73 x 80 cm. **PESO | WEIGHT:** 40 kg.





## 440103

### DISCOS 2 AGARRES PVC PAIK

PVC PLATES 2 GRIPS PAIK

- Discos con 2 agarres que permiten trabajar con barra o utilizar directamente el peso para tonificar diversos músculos del cuerpo, principalmente el tren superior.
- Fabricados en hierro con revestimiento de PVC, lo que los hace muy resistentes a los impactos, y aro interior en acero inoxidable de diámetro 50.
- Cómodos agarres integrados.
- Plates with grips that allow to work with a bar or use the weight directly to tone various muscles of the body, mainly the upper body.
- Made of steel with PVC coating, which makes them very resistant to impacts, and stainless steel inner ring diameter 50.
- Comfortable integrated grips.



#### DIMENSIONES | DIMENSIONS:

440103-0125: 1.25 kg. 185 x 185 x 28 mm.  
 440103-025: 2.5 kg. 230 x 230 x 28 mm.  
 440103-05: 5 kg. 300 x 300 x 30 mm.  
 440103-10: 10 kg. 335 x 335 x 40 mm.  
 440103-15: 15 kg. 390 x 390 x 43 mm.  
 440103-20: 20 kg. 430 x 430 x 45 mm.  
 440103-25: 25 kg. 455 x 455 x 50 mm.



## 440401

### DISCOS DE ACERO CAST IRON

STEEL PLATES CAST IRON

- Discos clásicos de hierro fundido para powerlifting, halterofilia y peso libre. Muy resistentes y un básico en los entrenamientos de fuerza.
- Para barras de Ø 50 mm.
- De 1.25 kg a 10 kg incluido se venden en múltiplos de 2 unidades.
- Classic cast iron plates for powerlifting, weightlifting and free weight. Very resistant and a basic in strength training.
- For Ø 50 mm bars.
- From 1.25 kg to 10 kg inclusive they are sold in multiples of 2 units.



#### DIMENSIONES | DIMENSIONS:

440401-0125: 1.25 kg. 166 x 166 x 12 mm.  
 440401-025: 2.5 kg. 210 x 210 x 15 mm.  
 440401-05: 5 kg. 238 x 238 x 22 mm.  
 440401-10: 10 kg. 272 x 272 x 34.5 mm.  
 440401-15: 15 kg. 350 x 350 x 33 mm.  
 440401-20: 20 kg. 442 x 442 x 33 mm.  
 440401-25: 25 kg. 442 x 442 x 37.5 mm.

## PTT0266

### RACK DE DISCOS

PLATES RACK

- Soporte para discos de diámetro 50 mm.
- Fabricado en hierro con terminación en epoxi color negro.
- Bases engomadas.
- Barras de almacenaje recubiertas de PVC.
- Uso profesional.
- Support for 50 diameter discs and bars.
- Made of iron with black epoxy finish.
- Gummed bases.
- PVC coated storage bars.
- Professional use.



DIMENSIONES | DIMENSIONS:  
 81 x 66.6 x 132 cm.

Dimensiones de la barras de almacenaje/Dimensions of the storage bar:  
 Ø 50 mm. x 20 cm. (largo/length).

PESO | WEIGHT:  
 26 kg.





- Incorporamos a nuestro catálogo taquillas a medida tanto en melamina como metálicas, 100% fabricadas en Jaén (España). Están disponibles en ancho de 30, 35 y 40 cm con la posibilidad de dividir entre una y cuatro puertas el espacio vertical de cada módulo. Disponibles en una gran variedad de colores. Solicita presupuesto personalizado a nuestro equipo.
- We include to our catalog custom lockers in both melamine and metal, 100% manufactured in Jaén (Spain). They are available in widths of 30, 35 and 40 cm with the possibility of dividing the vertical space of each module between one and four doors. Available in a wide variety of colors. Request a personalized quote to our team.





LOCKERS  
**TAQUILLAS**

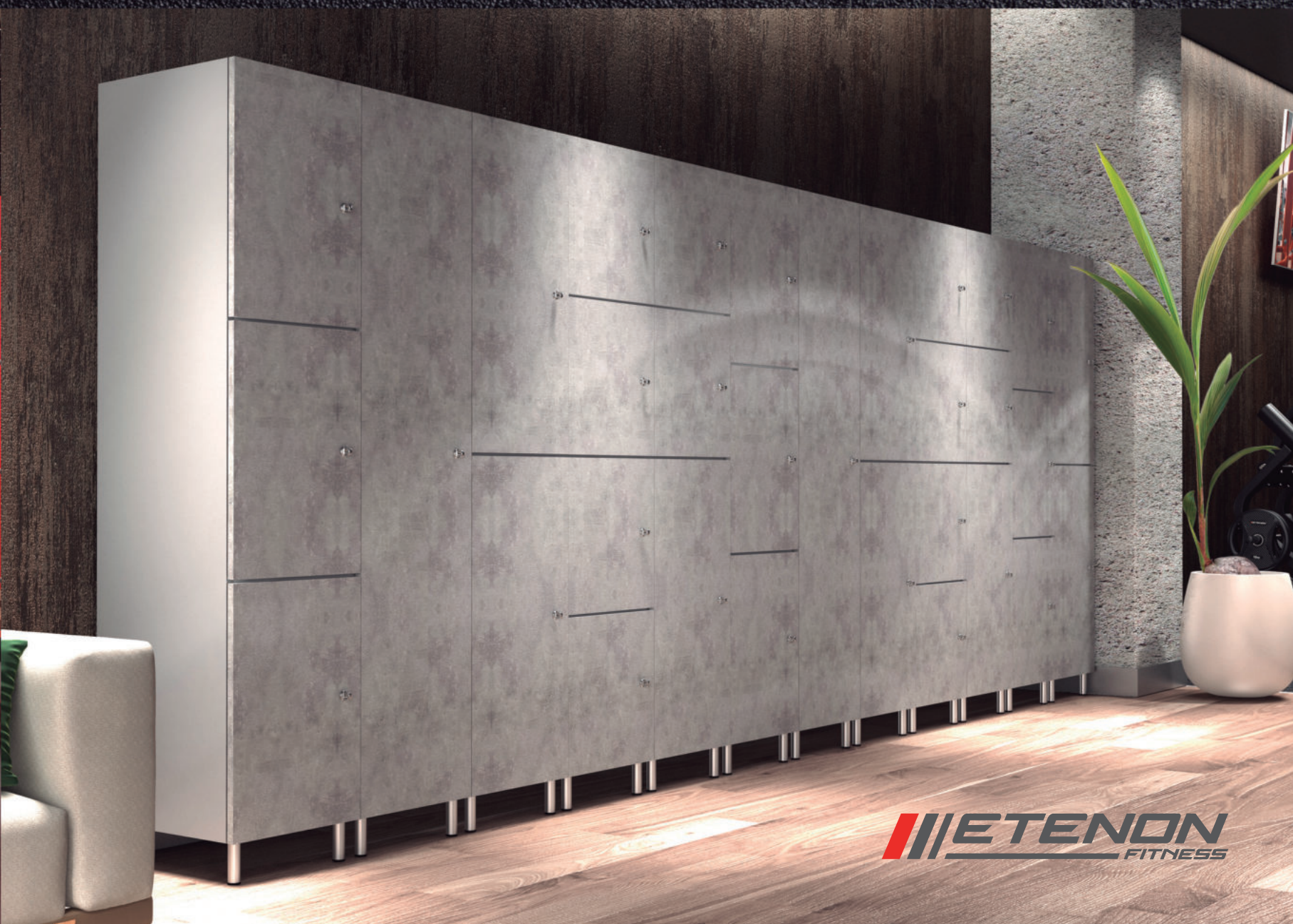
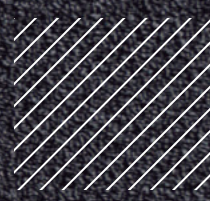

**ETENON**  
FITNESS

CARDIO & STRENGTH EQUIPMENT

# TU ÉXITO, NUESTRA META

*Configuramos tu proyecto*

Contacta con nosotros, ¡te asesoramos!

[info@etenonfitness.com](mailto:info@etenonfitness.com) / +34 953 28 44 85

[etenonfitness.com](http://etenonfitness.com)

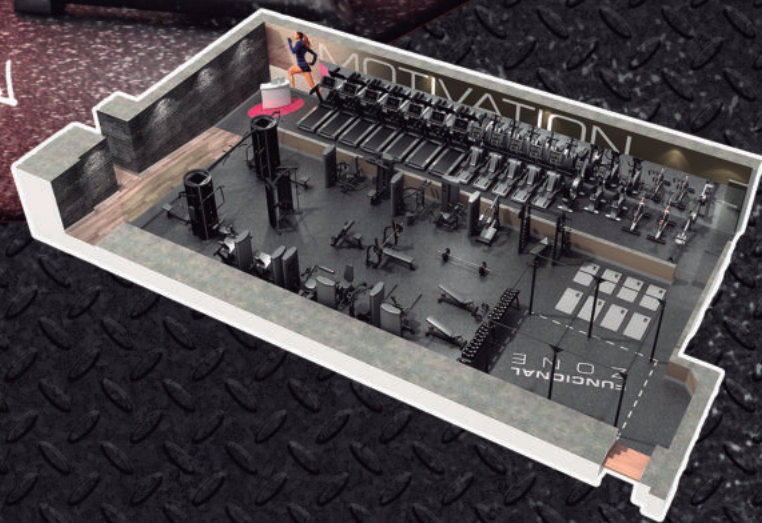

La confianza de nuestros clientes, es nuestro mayor logro.

**SYNERGYM**  
FIT TOGETHER



**FITNESS PARK**  
CHALLENGE - SUPERATE

**IVAN PERUJO**

**sano**

**énergie fitness**  
where you belong

**VIOA GYM**



**HOLMES PLACE**

**ALTA FIT GYM CLUB**

Los productos, descripciones e imágenes que aparecen en el catálogo se incluyen de modo ilustrativo, nunca contractual; sin que se pueda derivar reclamación y/o devolución. Etenon Fitness no se hace responsable de posibles errores de impresión de este catálogo.

The products, descriptions and images that appear in the catalog are solely illustrative, never contractual; no claim can be made and/or returned. Etenon Fitness is not responsible for possible printing errors in this catalog.